

ABSOLUTE ROTARY ENCODER INTERBUS



Main Features

- Compact and heavy duty industrial model
- Interface: INTERBUS Remote-Bus
- ENCOM-Profile: K3 (programmable)
- Housing: 58 mm Ø
- Shaft: 6 or 10 mm Ø, hollow- 15 mm Ø
- Resolution: max. 25 Bit = 33,554,432 steps over 4,096 revolutions
- Code: Binary

Programmable Parameters

- Direction of rotation (complement)
- Total resolution
- Preset value
- Zero Point Displacement
- Output of
 - parameter values
 - velocity
 - cam functions
- Optional:
 - Output of temperature

Mechanical Structure

- Flange and housing of Aluminum and Brass respectively
- Shaft of stainless steel
- Precision ball bearings with sealing or cover rings
- Code disc made of durable and unbreakable plastic

Electrical Features

- Temperature insensitive IR-Opto-Receiver-ASIC with integrated signal conditioning
- 400 Mio. write cycles
- Automatic end detection
- Highly integrated circuit with SMD technology
- Polarity inversion protection
- Over voltage peak protection

ABSOLUTE ROTARY ENCODER INTERBUS

Technical Data

Electrical Data

Supply voltage	10 - 30 V DC (absolute limits) *
Current consumption	Max. 3.5 Watt
EMC	EN 61000-6-2 (emitted interference), EN 61000-6-4 (interference resistance)
Interface	Line-driver according to RS 485 galvanically isolated by opto-couplers
Transmission rate	500 kBaud or 2 MBaud
Accuracy of division	$\pm \frac{1}{2}$ LSB
Step frequency LSB	Max. 800 kHz (valid code)
Electrical lifetime	$> 10^5$ h
Connector	9 pin circular plug

* Supply voltage according to EN 50 178 (safety extra-low voltage)

Mechanical Data

Housing	Aluminum, optional stainless steel		
Lifetime	Dependent on shaft version and shaft loading – refer to table		
Max. shaft loading	Axial 40 N, radial 110 N		
Inertia of rotor	≤ 30 gcm ²		
Friction torque	≤ 3 Ncm (without shaft sealing)		
RPM (continuous operation)	max. 12,000 RPM		
Shock (EN 60068-2-27)	≤ 30 g (halfsine, 11 ms)		
Permanent shock (EN 60028-2-29)	≤ 10 g (halfsine, 16 ms)		
Vibration (EN 60068-2-6)	≤ 10 g (10 Hz ... 1,000 Hz)		
Weight (standard version)	Singleturn:	≈ 500 g	
	Multiturn:	≈ 560 g	
Flange	Synchro (S)		Clamp (C)
Shaft diameter	6 mm	10 mm	10 mm
Shaft length	10 mm	20mm	20 mm
hollow shaft depth min. / max.	-	-	-
			Hollow shaft (B)
			15 mm
			-
			15 mm / 30 mm

ABSOLUTE ROTARY ENCODER INTERBUS

Minimum (mechanical) lifetime

Flange	Lifetime in 10 ⁸ revolutions with F _a / F _r		
	40 N / 60 N	40 N / 80 N	40 N / 110 N
C10 (Clamp flange 10 x 20)	247	104	40
S10 (Synchro flange 10 x 20)	262	110	42
S6 (Synchro flange 6 x 10) without shaft sealing	822	347	133

S6 (Synchro flange 6 x 10) with shaft sealing: max. 20 N axial, 80 N radial

Environmental Conditions

Operating temperature	- 0 .. +60 °C
Storage temperature	- 40 .. + 85 °C
Humidity	98 % (without liquid state)
Protection class (EN 60529)	Casing side: IP 65
	Shaft side: IP 64 (optional with shaft sealing: IP66)

ABSOLUTE ROTARY ENCODER INTERBUS

Interface

Installation

The rotary encoder is connected by two cables via 9-pin connectors, one as input line, the other one as output line. Each cable contains both power supply and the bus lines. To ensure the correct wiring, the input socket on the encoder has pins (male) whereas the output socket has holes (female). The address of the encoder is derived from its physical position in the network. The OCD is designed for a remote bus with up to 32 bits of I/O data. In the master (controller) the actual process values occupy one or two word addresses for profile K1 or K2 and K3, respectively.

Male (IB-In)	Signal	Female (IB-Out)
1	DO	1
2	\overline{DO}	2
3	DI	3
4	\overline{DI}	4
5	GND	5
6	PE	6
7	+ 10-30 V DC	7
8	GND (0V)	8
9	NC	9

IB-Coupling	Class	Max. Bits	Progr.	No. of words	ID-Code	
					Binary	Hex
Remote bus	K1	16	no	1 IN	0000 0001 0011 0110	0136
Remote bus	K2	32	no	2 IN	0000 0010 0011 0110	0236
Remote bus	K3	32	yes	2 IN + 2 OUT	0000 0010 0011 0111	0237

Connection on the 2-wired Installation Remote Bus

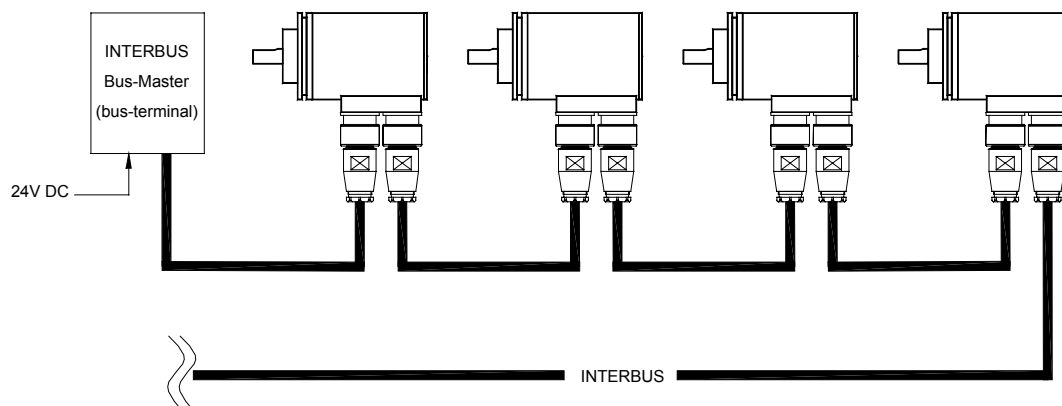

ABSOLUTE ROTARY ENCODER INTERBUS

Programmable Parameters

The Interbus encoder supports the programmable encoder profiles K1, K2 or K3 of the ENCOM*. The following parameters can be programmed directly via the INTERBUS network without any extra devices:

Code sequence	As an operating parameter the code sequence (complement) can be programmed. This parameter determines whether the output code increases or decreases when the axis is turned clockwise.
Output steps over number of revolutions	This parameter defines the number of measuring steps over the number of revolutions described below.
Number of revolutions	This parameter determines the number of revolutions used to calculate the steps per revolution. For example: Total resolution=8, Revolutions=2, then the Steps per revolution will be equal to 4. This value must always be less than the total allowed revolutions (for a multi-turn, 4,096).
Preset value	The preset value is the desired output value for the actual position of the axis. The actual output value will be set to this preset value.
Zero point displacement	This parameter sets the zero point of the output in relation to the physical zero point position of the encoder. (same functionality as preset value)
Velocity (Optional)	Optionally, the current rotational velocity of the axis can be output in revolutions per minute.
Read-out parameter values and temperature (Optional)	Optional all parameter values, certain other information (specified in the manual) and the temperature value of an additional temperature sensor can be read out via the bus
Cam functions	Cam functions which are entirely programmable via the bus are integrated in the encoder.

* ENCOM: User group of encoder manufacturers in the INTERBUS club.

ABSOLUTE ROTARY ENCODER INTERBUS

Mechanical Drawings

Synchro flange

Two versions available

Synchro flange	d [mm]	l [mm]
Version S06	$\varnothing 6_{f6}$	10
Version S10	$\varnothing 10_{h8}$	20

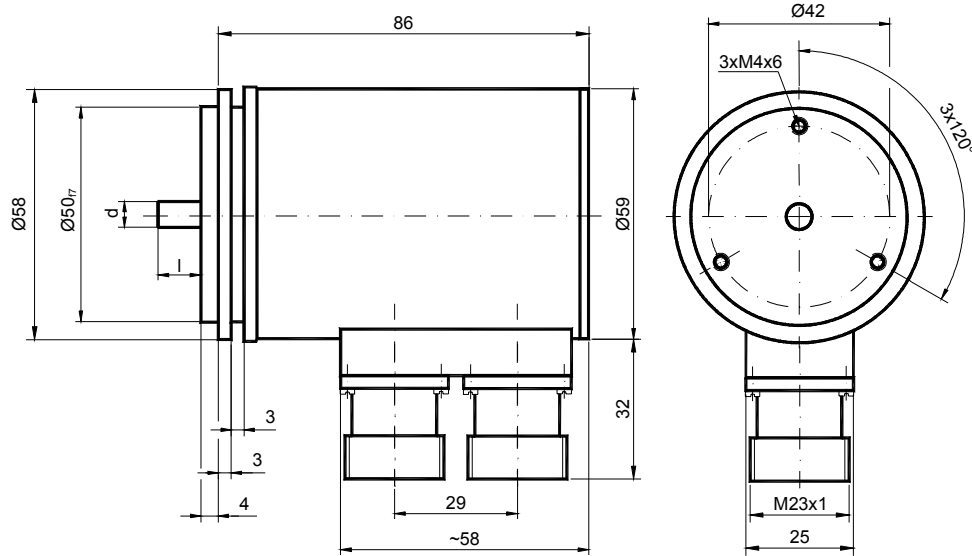

Clamp flange

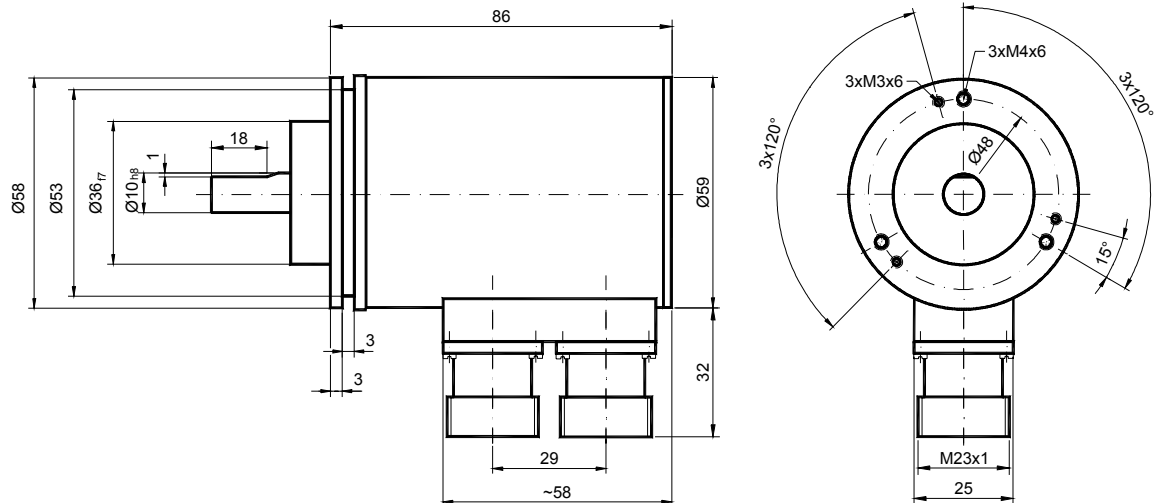

ABSOLUTE ROTARY ENCODER INTERBUS

Models / Ordering Description

Description	Type Key										
Optocode	OCD	-IB	A1	B -	---	---	-	---	-	PRI	----
Interface Interbus	IB										
Version			A1								
Code	Binary			B							
Bits for revolutions	Single-turn				00						
	Multi-turn				12						
Steps per revolution	4,096				12						
	8,192				13						
Flange	Clamp flange						C				
	Synchro flange						S				
	Blind hollow shaft						B				
Shaft	ø10 mm						10				
	ø06 mm						06				
	ø15 mm (only for hollow shaft)						15				
Mechanical options	Without						0				
	Shaft sealing						S				
	Customized						C				
Connection	Connector radial								PRI		
Options	number for special options										

Standard = bold, further models on request

ABSOLUTE ROTARY ENCODER INTERBUS

Accessories and Documentation

Description		Type
Connector counterpart	9 pin circular connector, male	0SG-S
Connector counterpart	9 pin circular connector, female	0SG-B
Shaft coupling **	Drilling: 10 mm	GS 10
	Drilling: 6 mm	GS 06
Clamp disc **	4 pcs. / AWC	SP 15
Clamp ring **	2 pcs. / AWC	SP H
Reducing adapter ***	15 mm to 12 mm	RR12
Reducing adapter ***	15 mm to 10 mm	RR10
Reducing adapter ***	15 mm to 8 mm	RR8
User manual*	Installation and configuration manual for Interbus, German	UMD-IB
User manual*	Installation and configuration manual for Interbus, English	UME-IB
Programming software *	Floppy disc with programming software for Windows and the Phoenix PC-ISA Master Card	DK-IB

* These can be downloaded free of charge from our homepage www.posital.de.

** not for hollow shaft

*** only for hollow shaft

We do not assume responsibility for technical inaccuracies or omissions. Specifications are subject to change without notice.