

INCLINOMETER
CANOPEN



Main Features

- Two axis digital inclinometer
- Angle measurement range of $\pm 5^\circ$, $\pm 15^\circ$ and $\pm 30^\circ$, Resolution up to 0.001°
- Active linearization and temperature compensation
- Interface: CAN according to CAL
- Code: Binary
- Housing: 70 mm \varnothing

Programmable Parameters

- Resolution
- Preset value
- Two limit switches
- Baud-rate and CAN-identifier
- Heartbeat Function
- Transmission mode: Polled mode, cyclic mode, sync mode

Electrical Features

- Highly integrated circuit in SMD-technology
- Polarity inversion protection
- Over-voltage-peak protection

Applications

- Structural engineering
- Levelling techniques
- Measuring techniques
- Inclinations
- Mechanical Structure

INCLINOMETER CANOPEN

Technical Data

Electrical Data

Model	AGS 5	AGS 15	AGS 30
Measuring range	+/- 5°	+/- 15°	+/- 30°
Resolution	0.001°	0,001°	0,005°
Accuracy (T = 0 °C .. +55 °C)	0,06°	0,18°	0,40°
Accuracy (T = -25 °C . +85 °C)	0,12°	0,30°	1,00°
Inclination angle in x and y (1)	+/-15°	+/-40°	+/-60°
Damping period 0° -> 5°	typical 1s 10%, 2s 1%, 3s 0,1%		
Interface	Transceiver according ISO 11898, galvanically isolated by opto-couplers		
Transmission rate	max. 1 MBaud		
Device addressing	Adjustable by rotary switches in connection cap		
Supply voltage (2)	10 – 30 V DC (absolute limits)		
Current consumption	max. 230 mA with 10 V DC, max. 100 mA with 24 V DC		
Power consumption	max. 2.2 Watts		
EMC	Emitted interference: EN 61000-6-4		
	Noise immunity: EN 61000-6-3		
Electrical lifetime	> 10 ⁵ h		

(1) Supply voltage is applied.

(2) Inclinometers should be connected only to subsequent electronics whose power supplies comply with EN 50178 (protective low voltage)

Mechanical Data

Housing	Aluminum
Lifetime	> 10 ⁵ h
Shock	A=30g; t= 11ms, halfsine (EN 60068-2-27)
Vibration	10 to 150 Hz, 2,5 mm amplitude, 5g const. Acceleration, 1 Octave /Minute (EN 60068-2-6)
Weight (standard version)	350 g

Environmental Conditions

Operating temperature	-40°C.....+85°C
Storage temperature	-40°C.....+85°C
Humidity	98 % (without liquid state)
Protection class	IP 67 (connected) (EN 60529)

INCLINOMETER CANOPEN

Installation

Electrical Connection

The inclinometer is connected via 8 pin round connector or a Cable

Instructions to mechanically install and electrically connect the inclinometer



Do not connect the inclinometer under power!



Do not stand on the inclinometer!



Avoid mechanical load!

There is a resistor provided in the inclinometer, which must be used as a line termination on the last device.



Bus address

The setting of the node number is achieved via SDO-Object (see 4.2). Possible (valid) addresses lie between 0 and 96 whereby every address can only be used once.

Bus Termination

If the inclinometer is connected at the end or beginning of the bus the termination resistor must be switched on. The termination resistor is switched on when the dip-switch 8 is in the 'ON' position. To switch the resistor on, the cap of the inclinometer have to unscrew.



The CANopen inclinometer adds internal 1 to the adjusted device address.

Pin	Description	P8F-Cable	CRW-Cable *
1	+UB Supply voltage	White	white (3)
2	RxD	Brown	
3	TxD	Green	
4	Ground (Supply)	Yellow	brown (10)
5	CAN Low	grey	pink (13)
6	CAN Ground	Pink	green (12)
7	CAN High	Blue	yellow (5)
8		Red	

Tabelle 1 Connector Assignment

* 15 pin D-Sub Connector

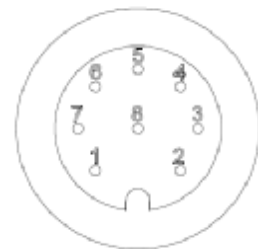

Front view of housing
Connector inclinometer

INCLINOMETER CANOPEN

Programmable Encoder - Parameter

Resolution per 1°	The parameter resolution per 1° is used to program the desired number of steps per revolution. The values 1, 10, 100 and 1000 can be programmed.
Preset Value	The preset value is the desired position value, which should be reached at a certain physical position of the axis. The position value is set to the desired process value by the parameter pre-set.
Baudrate	The Baudrate can be programmed via SDO, default 20KBaud .
Node Number	The setting of the node number is achieved via SDO-Object. Possible (valid) addresses lie between 0 and 89 whereby every address can only be used once. The CANopen inclinometer adds internal 1 to the adjusted device address. Default 20Hex

Programmable CAN Transmission Modes

Polled Mode	By a remote-transmission-request telegram the connected host calls for the current process value. The inclinometer reads the current position value, calculates eventually set-parameters and sends back the obtained process value by the same identifier.
Cyclic Mode	The inclinometer transmits cyclically - without being called by the host - the current process value. The cycle time can be programmed in milliseconds for values between 1 ms and 65536 ms.
Sync Mode	After receiving a sync telegram by the host, the inclinometer answers with the current process value. If more than one node number (encoder) shall answer after receiving a sync telegram, the answer telegrams of the nodes will be received by the host in order of their node numbers. The programming of an offset-time is not necessary. If a node should not answer after each sync telegram on the CAN network, the parameter sync counter can be programmed to skip a certain number of sync telegrams before answering again.
Heartbeat-Function	A node signaled his communication status by transmitting cyclically a heartbeat message. This message could receives one, divers or each member (Heartbeat Consumer) in the bus and so they can control the dedicated node(Heartbeat Producer).

INCLINOMETER CANOPEN

Mechanical Drawings

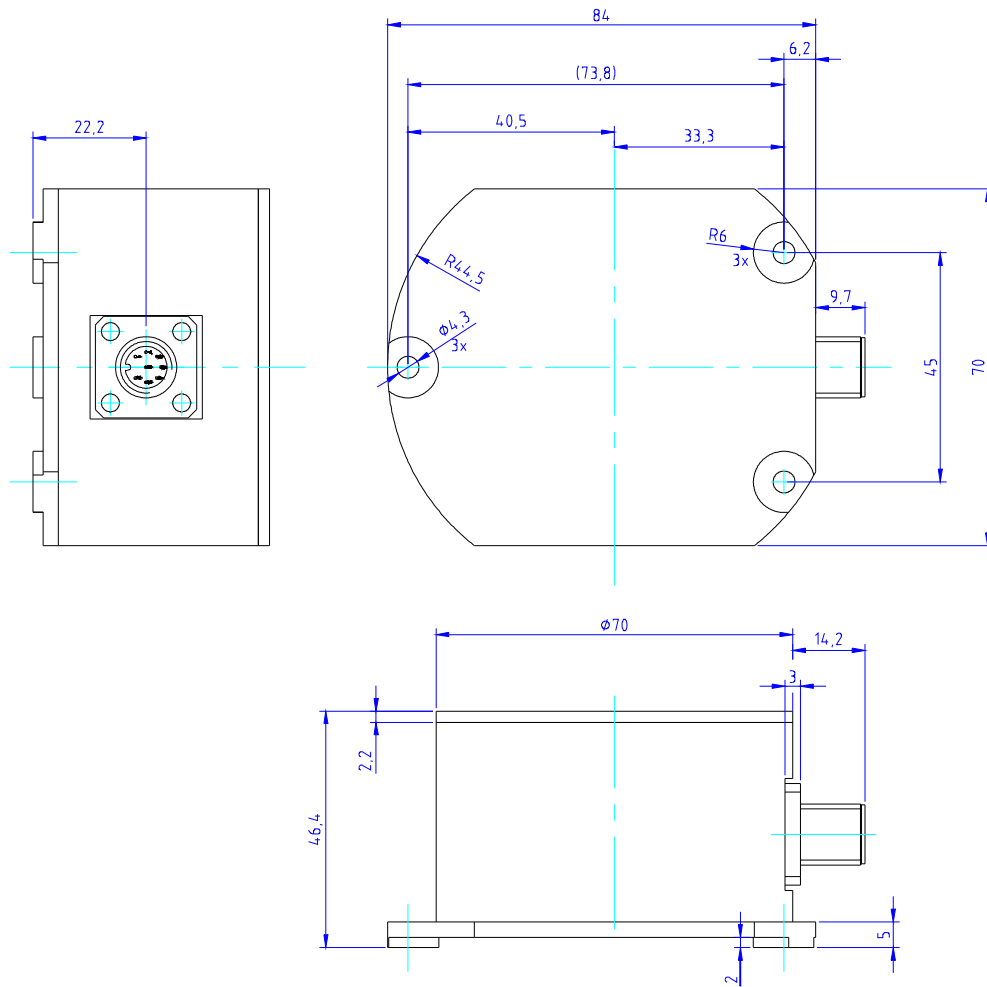

Dimension housing (mm)

INCLINOMETER
CANOPEN

Reference Level

The Inclinator has a mounting reference angel (black line)for an optimal mounting of the inclinometer, which is parallel to the x-axis. This reference angle must be placed exactly parallel to the object to be measured to prevent or minimize any mechanical offset/cross sensitivity.

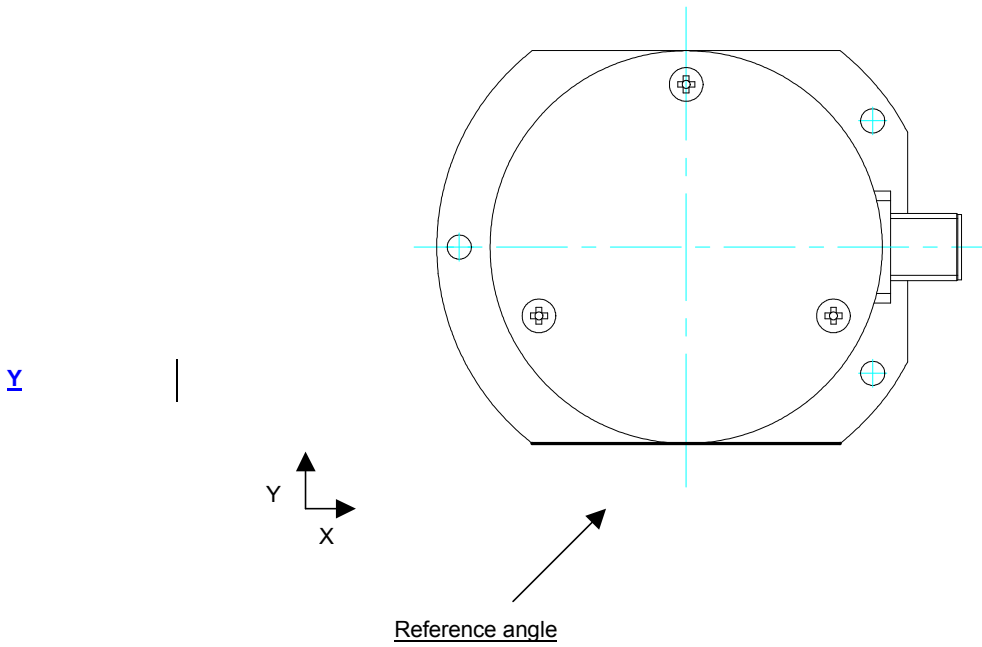

Reference angle of the inclinometer, top view.

INCLINOMETER CANOPEN

Mounting and Installation Instruction

The inclinometer is designed for a horizontal mounting, i.e. the base plate of the inclinometer with the three mounting holes needs to be placed on the horizontal plane of the object to be measured. It can be mounted with M4 screw as a maximum.

The mounting surface must be plane and free of dust and grease.

We recommend cheese head screws with metrical thread M4 for the mounting.

Maximum fastening torque for the mounting screws is 10 Nm.

Installation

Prior to installation, please check for all connection and mounting instructions to be complied with. Please also observe the general rules and regulations on low voltage technical devices.

Avoid shock and vibration during measurement, as these could corrupt the measurement results. Inclination sensors that base on a fluidic measurement principle are optimal for static measurements and suitable to only a limited extent of dynamic measurement.

Measurement

The measurement of the tilt angle of the single measurement axis is carried out over the respective longitudinal and lateral axis of the inclination sensor. Reference is always the horizontal plane.

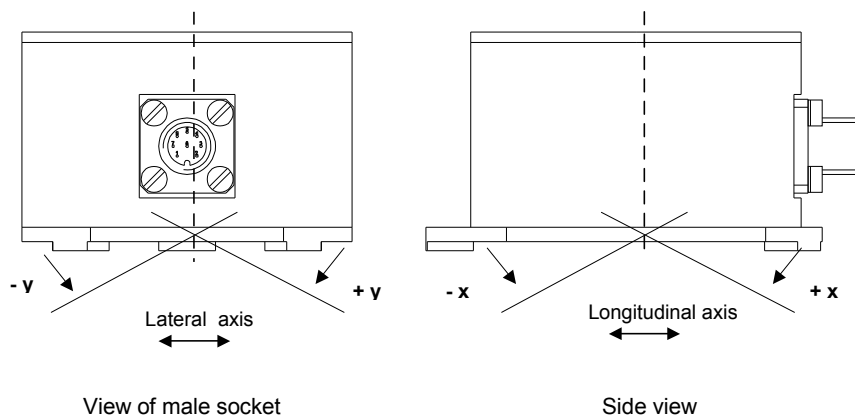

INCLINOMETER CANOPEN

Models/Ordering Description

Description	Typekey
Absolute inclinometer	AGS . . . -2- . . 1- H0- . . . -
Measuring range	005 015 030
Number of axis	
Interface	CA
Version	
Mechanical construction	horizontal
Dynamik	2 mPas
Connection	connector, 8 pin 1 m cable
Option	without

Tabelle 2 Ordering Description

Accessories and documentation

Description	Typ
Mating Connector	P8F
Cabel	Cabel STK 8, 2m, Connector P8F
	Cabel STK 8, 5m, Connector P8F
User manual *	Installation and configuration manual, german
User manual *	Installation and configuration manual, english
EDS-File *	Disc containing EDS-file for configuration

Tabelle 3 Accessories

* These can be downloaded free of charge from our homepage www.posital.com.

We do not assume responsibility for technical inaccuracies or omissions. Specifications are subject to change without notice.