

ABSOLUTE INCLINOMETER DEVICE NET



Main Features

- Compact and heavy duty industrial model
- Interface: DeviceNet
- Code: Binary
- Resolution: Up to 0,001°
- Accuracy: Up to 0.15°
- Viscosity: 2 mPas
(22 and 44 mPas on request)

Applications

- Structural engineering
- Levelling techniques
- Measuring techniques
- Inclinations
- Mechanical Structure

Mechanical Structure

- Housing of Aluminum
- Protection class: IP66 with connection cap

Electrical Features

- status indication with two LEDs in the connection cap
- Linear and temperature compensated characteristic line
- Microprocessor controlled
- Highly integrated circuit in SMD-Technology
- Polarity inversion protection
- Over-voltage-peak protection

ABSOLUTE INCLINOMETER DEVICE NET

Technical Data

Electrical Data

| | | |
|-----------------------------------|--|------------|
| Model | ANS 15 | ANS 30 |
| Measuring range | +/- 15° | +/- 30° |
| Resolution | 0.001° | 0.01° |
| Accuracy (T = 0 °C .. +55 °C) | 0.15° | 0,2 |
| Accuracy (T = -25 °C .. +85 °C) | 0.3° | 0,4 |
| Damping period (0° -> 15°, t=90%) | Typ. 2.5 s | on request |
| Supply voltage | 10 - 30 V DC | |
| Power consumption | 2.2 Watts | |
| EMV | EN 50081-2, EN 61000-6-2 | |
| Connection to CAN-bus | Galvanically isolated by opto couplers, up to 64 nodes CAN transceiver according to ISO 11898 | |
| Connection | Accessory connection cap, IP 66 optional: Binder connector in connection cap, IP 66 | |
| Cycle time | Typ. 4 measurements / second (because of measuring principle) | |
| Electrical lifetime | > 10 ⁵ h | |
| Node number, baud rate | configured via rotary switches in the connection cap | |

Environmental Conditions

| | |
|-------------------------------|--|
| Operating temperature | - 25 °C to + 80 °C |
| Storage temperature | - 40 °C to + 85 °C |
| Humidity | 98 % (without liquid state) |
| Protection class (DIN 40 050) | IP 66 (with connection cap in connected state) |

ABSOLUTE INCLINOMETER DEVICE NET

Interface

Installation connection cap

The inclinometer is connected by two or three cables depending on whether the power supply is integrated into the bus cable or connected separately. If the power supply is integrated into the bus cable, one of the cable glands can be fitted with a plug. The cable glands are suitable for cable diameters from 5.5 up to 9 mm.

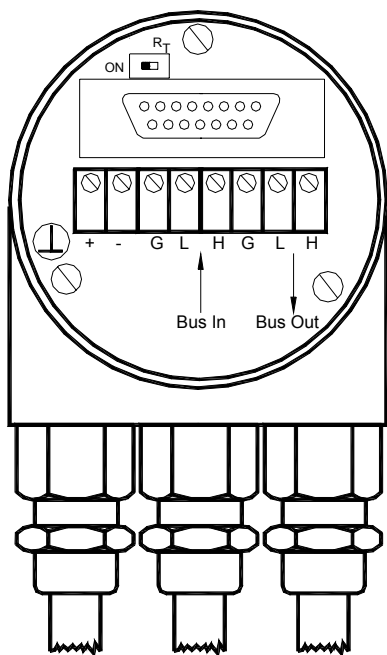

Configuration connection cap

The setting of the node number is achieved by 2 turn-switches in the connection cap. Possible addresses lie between 0 and 63 whereby every address can only be used once. The connection cap can easily be opened for installation by removing the two cap screws.

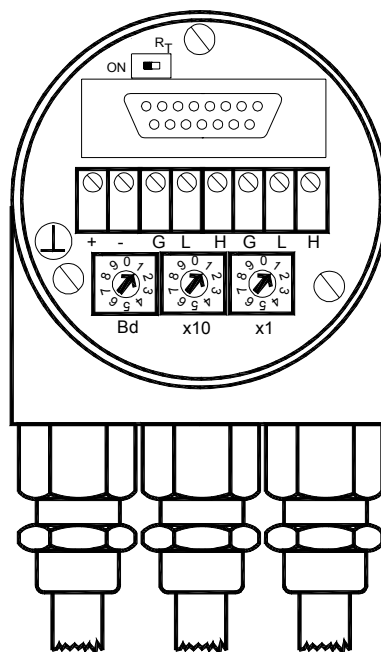

| Clamp | Description |
|-----------|----------------------|
| ⊥ | Ground |
| + | 24 V Supply voltage |
| - | 0 V Supply voltage |
| G (left) | CAN Ground (Bus In) |
| L (left) | CAN Low (Bus In) |
| H (left) | CAN High (Bus In) |
| G (right) | CAN Ground (Bus Out) |
| L (right) | CAN Low (Bus Out) |
| H (right) | CAN High (Bus Out) |

A termination resistor is integrated in the connection cap. The resistor must be switched on if the inclinometer is connected at the end or at the beginning of the bus. Separation of Bus In and Bus Out signals if termination resistor is activated.

Resistor:

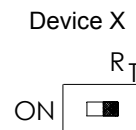
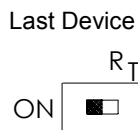

ABSOLUTE INCLINOMETER DEVICE NET

Diagnostic connection cap

Two LEDs on the backside of the connection cap show the operating status of the inclinometer.

This can be very useful for installing and setting-up the sensor.

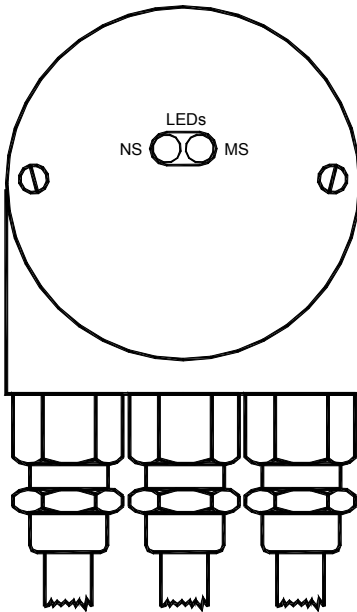

Connection cap with round connector

The connection cap type AH58-B1DA-1BW is equipped with a 5 pole connector in M12 dimensions. All other cable glands are replaced by blind caps.

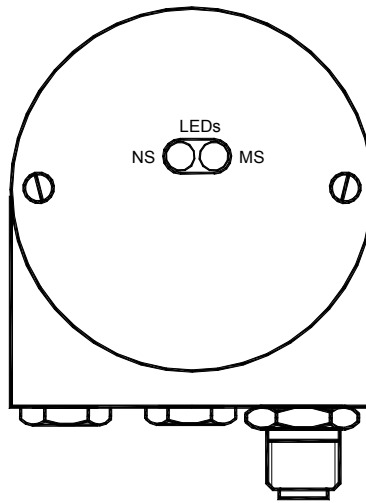

Following table indicates pinning of the micro style connector:

| Pin number | Signal |
|------------|---------------------|
| 1 | (CAN Ground) |
| 2 | 24 V Supply voltage |
| 3 | 0 V Supply voltage |
| 4 | CAN High |
| 5 | CAN Low |

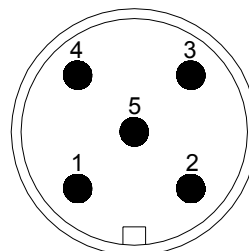

Pinning (Male)

ABSOLUTE INCLINOMETER DEVICE NET

Mechanical Drawings

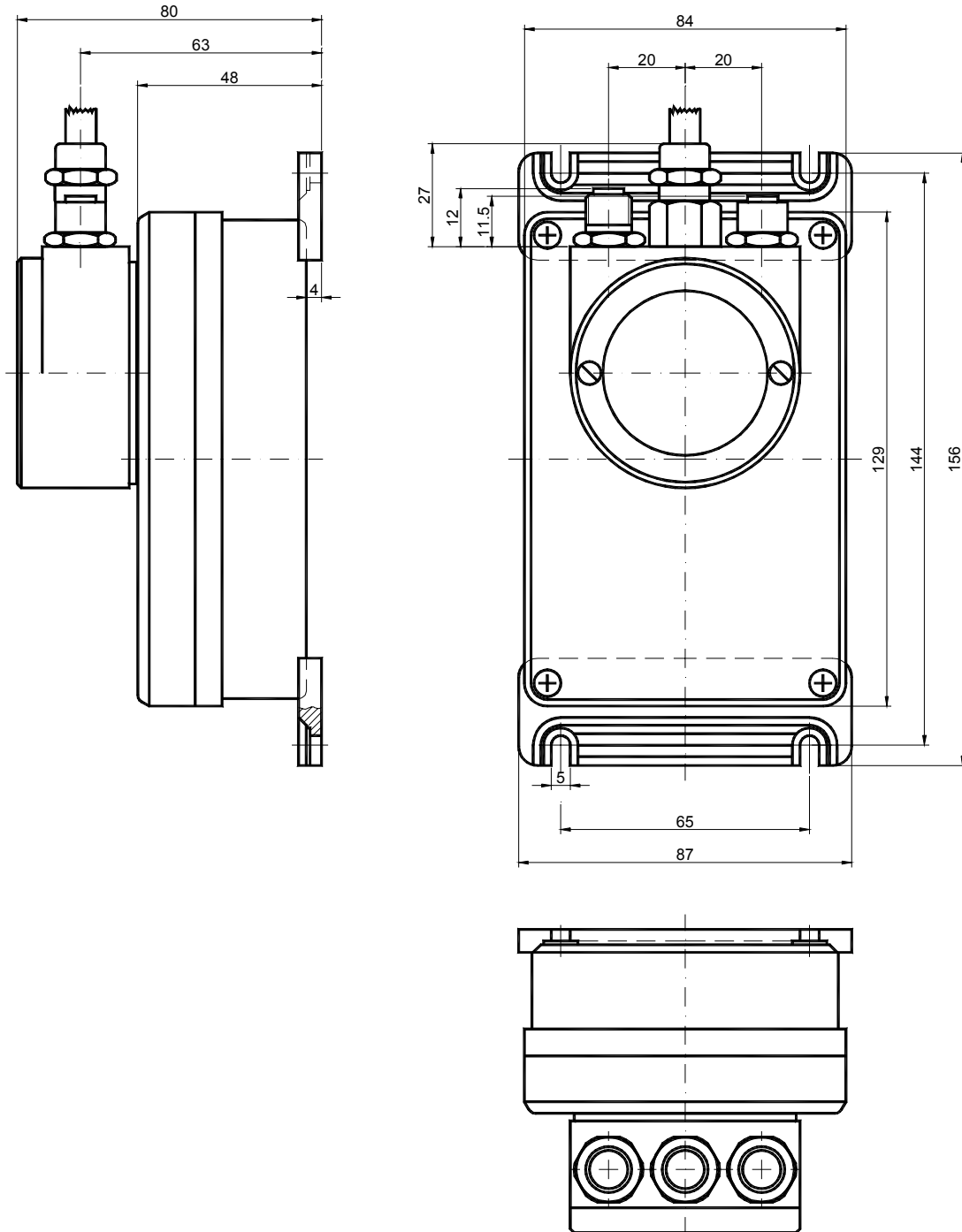

**ABSOLUTE INCLINOMETER
DEVICE NET**

Programmable Inclinometer-Parameters

| | |
|-----------------------|---|
| Preset Value X/Y-Axis | The preset value is the desired inclination value, which should be reached at a certain physical inclination of the sensor axis. The inclination value is set to the desired process value by the parameter preset independent for X- and Y-axis. |
|-----------------------|---|

Programmable CAN Transmission Modes

| | |
|-----------------|---|
| Polled Mode | By a telegram the connected host calls for the current process value. The inclinometer reads the current inclination value, calculates eventually set-parameters and sends back the obtained process value. |
| Change of State | The inclinometer transmits the actual process value. The process value is transmitted when the inclination changes. This is useful to reduce the bus activity. |
| Cyclic | The inclinometer transmits the actual process value event controlled by an internal timer. This is also useful to reduce the bus activity. |

ABSOLUTE INCLINOMETER DEVICE NET

Models / Ordering Description

| | | | | | |
|-----------------------|---------------------------|-----------|-----------|----------|------------|
| Description | Type Key | | | | |
| Absolute inclinometer | ANS | . | . | - | - |
| Measuring range | | 15 | | | |
| | | 30 | | | |
| CAN-Interface | | | D2 | | |
| Version | | | | 1 | |
| Number of axis | | | | | 2 |
| Connection | Connection *1) | | | | 3PG |
| Options | Without | | | | - |
| Special version | Protective membrane vents | | | | E |

*1)The connection cap has to be ordered seperately !

Standard = bold, further models on request

Accessories and Documentation

| Description | | Type |
|-------------------|---|---------------|
| Connection cap*1) | T-coupling-functionality with integrated address setting is necessary to use the inclinometer | |
| | Standard | AH58-B1DA-3PG |
| | Connection with 5pin round connector, Micro style | AH58-B1DA-1BW |
| EDS-file *2) | Disc containing EDS-file for configuration | DK-ANS-D2 |
| User manual *2) | Installation and configuration manual for ANS-CAN, English | UME-ANS-D2 |
| User manual *2) | Installation and configuration manual for ANS-CAN, German | UMD-ANS-D2 |

*2) These can be downloaded free of charge from our homepage www.posital.com.

We do not assume responsibility for technical inaccuracies or omissions. Specifications are subject to change without notice.