

ABSOLUTE INCLINOMETER CAN



Main Features

- Interface: CAN-bus
- Code: Binary
- Resolution: Up to 0,001°
- Accuracy: Up to 0.15°
- Viscosity: 2 mPas
(22 and 44 mPas on request)

Applications

- Structural engineering
- Levelling techniques
- Measuring techniques
- Inclinations
- Mechanical Structure

Mechanical Structure

- Housing of Aluminum
- Protection class: IP66 with connection cap

Electrical Features

- status indication with two LEDs in the connection cap
- Linear and temperature compensated characteristic line
- Microprocessor controlled
- Highly integrated circuit in SMD-Technology
- Polarity inversion protection
- Over-voltage-peak protection

ABSOLUTE INCLINOMETER CAN

Technical Data

Electrical Data

Model	ANS 15	ANS 30
Measuring range	+/- 15°	+/- 30°
Resolution	0.001°	0.01°
Accuracy (T = 0 °C .. +55 °C)	0.15°	0,2°
Accuracy (T = -25 °C .. +85 °C)	0.3°	0,4°
Damping period (0° -> 15°, t=90%)	Typ. 2.5 s	on request
Supply voltage	10 - 30 V DC	
Power consumption	2.2 Watts	
EMV	EN 50081-2, EN 61000-6-2	
Connection to CAN-bus	Galvanically isolated by opto couplers CAN transceiver according to ISO 11898	
Connection	Accessory connection cap, IP 66 optional: Binder connector in connection cap, IP 66	
Cycle time	Typ. 4 measurements / second (because of measuring principle)	
Electrical lifetime	> 10 ⁵ h	
Node number, baud rate	configured via rotary switches in the connection cap	

Environmental Conditions

Operating temperature	- 25 °C to + 80 °C
Storage temperature	- 40 °C to + 85 °C
Humidity	98 % (without liquid state)
Protection class (DIN 40 050)	IP 66 (with connection cap in connected state)

ABSOLUTE INCLINOMETER CAN

Interface

Installation connection cap

The inclinometer is connected by two or three cables depending on whether the power supply is integrated into the bus cable or connected separately. If the power supply is integrated into the bus cable, one of the cable glands can be fitted with a plug. The cable glands are suitable for cable diameters from 5.5 up to 9 mm.

Configuration connection cap

The setting of the node number is achieved by 2 turn-switches in the connection cap. Possible addresses lie between 0 and 90 whereby every address can only be used once. Inside the inclinometer the defined address is increased by one. The connection cap can easily be opened for installation by removing the two cap screws.

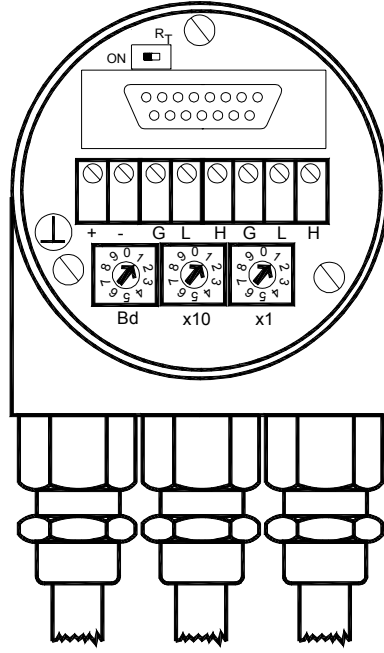
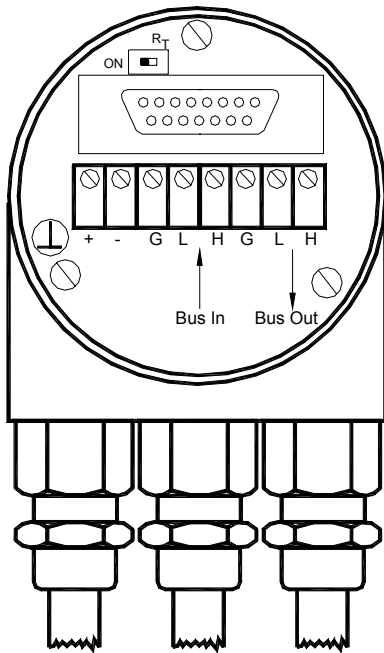

Clamp	Description
⊥	Ground
+	24 V Supply voltage
-	0 V Supply voltage
G (left)	CAN Ground (Bus In)
L (left)	CAN Low (Bus In)
H (left)	CAN High (Bus In)
G (right)	CAN Ground (Bus Out)
L (right)	CAN Low (Bus Out)
H (right)	CAN High (Bus Out)

A termination resistor is integrated in the connection cap. The resistor must be switched on if the inclinometer is connected at the end or at the beginning of the bus. Separation of Bus In and Bus Out signals if termination resistor is activated.

Resistor:

Last Device



Device X



ABSOLUTE INCLINOMETER CAN

Diagnostic connection cap

Two LEDs on the backside of the connection cap show the operating status of the inclinometer.

This can be very useful for installing and setting-up the sensor.

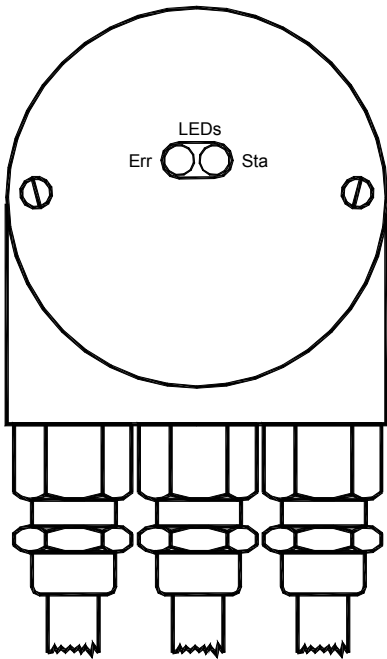

Connection cap with round connector

The connection cap type AH58-B1CA-1BW is equipped with a 5 pole connector in M12 dimensions. All other cable glands are replaced by blind caps.

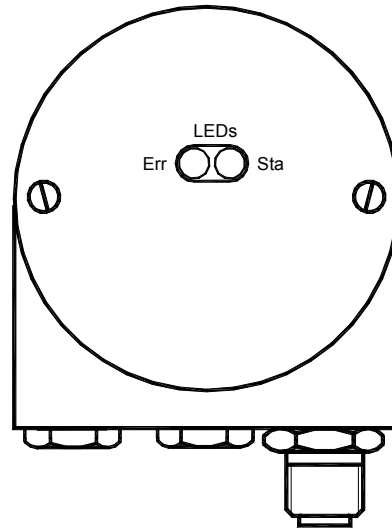

Following table indicates pinning of the micro style connector:

Pin number	Signal
1	(CAN Ground)
2	24 V Supply voltage
3	0 V Supply voltage
4	CAN High
5	CAN Low

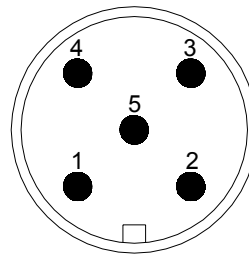

Pinning (Male)

ABSOLUTE INCLINOMETER CAN

Mechanical Drawings

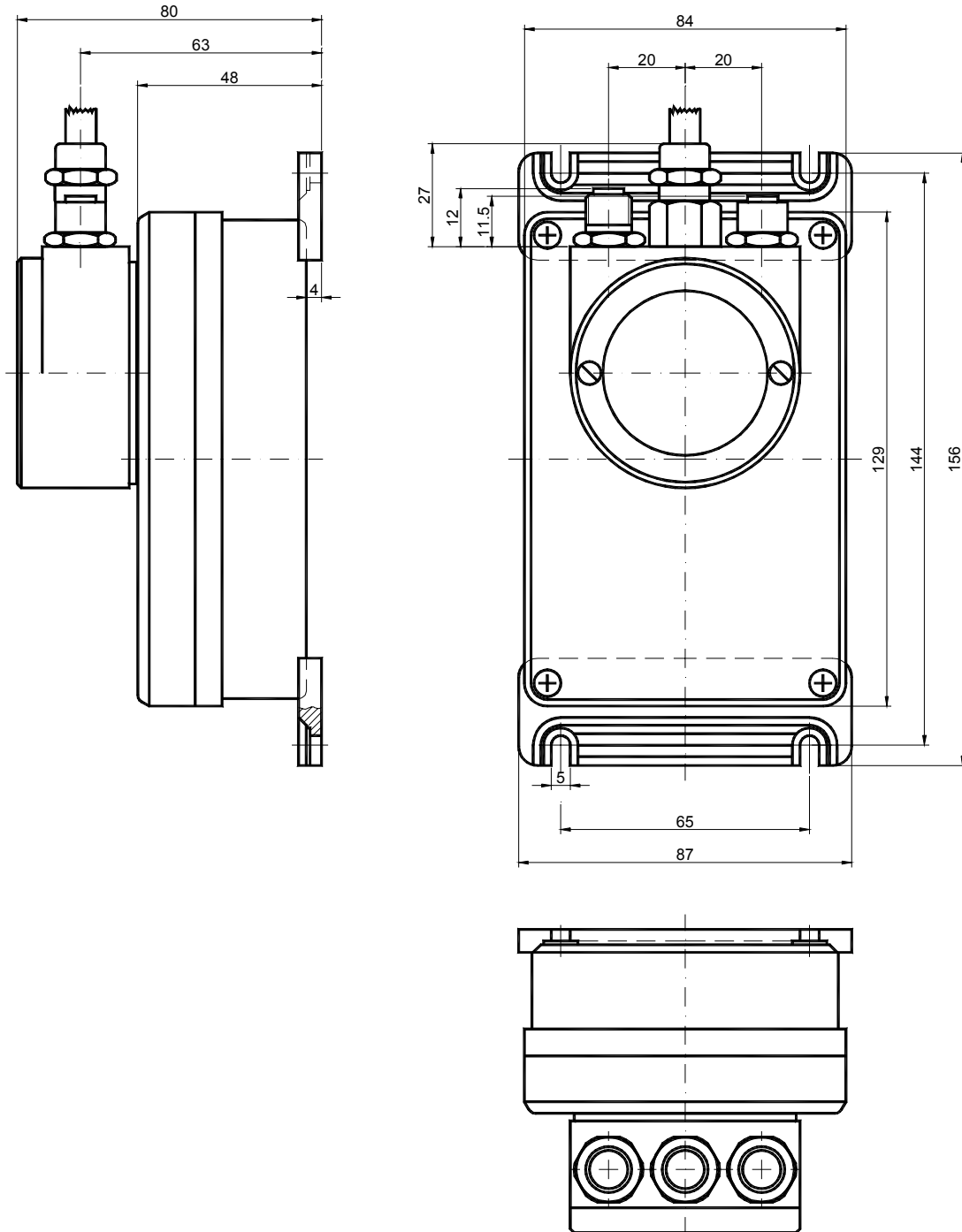

ABSOLUTE INCLINOMETER CAN

Programmable Inclinometer-Parameters

Preset Value X/Y-Axis	The preset value is the desired inclination value, which should be reached at a certain physical inclination of the sensor axis. The inclination value is set to the desired process value by the parameter preset independent for X- and Y-axis.
Alarm bit X/Y-Axis	In addition to the inclination value it is possible to transmit a status byte which indicates if the measuring range is exceeded.

Programmable CAN Transmission Modes

Polled Mode	By a remote-transmission-request telegram the connected host requests the current process value. The inclinometer reads the current inclination value, calculates eventually set-parameters and sends back the obtained process value by the same identifier.
Cyclic Mode	The inclinometer transmits cyclically - without being called by the host - the current process value. The cycle time can be programmed in milliseconds for values between 1 ms and 65536 ms.
Sync Mode	After receiving a sync telegram by the host, the inclinometer answers with the current process value. If more than one node number (inclinometer) shall answer after receiving a sync telegram, the answer telegrams of the nodes will be received by the host in order of their node numbers. The programming of an offset-time is not necessary. If a node should not answer after each sync telegram on the CAN network, the parameter sync counter can be programmed to skip a certain number of sync telegrams before answering again.

ABSOLUTE INCLINOMETER CAN

Models / Ordering Description

Description	Type Key				
Absolute inclinometer	ANS	.. -			-
Measuring range		15			
		30			
CAN-Interface			C2		
Version				1	
Number of axis					2
Connection	Connection *1)				3PG
Options	Without				-
Special version	Protective membrane vents				E

*1)The connection cap has to be ordered seperately !

Standard = bold, further models on request

Accessories and Documentation

Description		Type
Connection cap*1)	T-coupling-functionality with integrated address setting is necessary to use the inclinometer	
	Standard	AH58-B1CA-3PG
	Connection with 5pin round connector, Micro style	AH58-B1CA-1BW
EDS-file *2)	Disc containing EDS-file for configuration	DK-ANS
User manual *2)	Installation and configuration manual for ANS-CAN, English	UME-ANS
User manual *2)	Installation and configuration manual for ANS-CAN, German	UMD-ANS

*2) These can be downloaded free of charge from our homepage www.posital.com.

We do not assume responsibility for technical inaccuracies or omissions. Specifications are subject to change without notice.