

## Absolute Rotary Encoder EXAG – Explosion Proof

### Canopen



#### Main Features

- Approval:  II 2 G/D EEx d II C T6
- Heavy-duty industrial model
- Interface: CAN
- Protocol: Canopen
- Max. 65536 steps per revolution (16 Bit)
- Max. 16384 revolutions (14 Bit)
- Code: Binary

#### Mechanical Structure

- Ex-proof, flameproof enclosure
- Flange and housing of Aluminum
- Shaft of stainless steel
- Precision ball bearings with sealing or cover rings
- Code disc made of unbreakable and durable plastic

#### Programmable Parameters

- Direction of rotation (complement)
- Resolution per revolution
- Total resolution
- Preset value
- Cams
- Two limit switches
- Transmission mode: Polled mode, cyclic mode, sync mode, or change of state mode

#### Electrical Features

- Address and baudrate setting via rotary switches
- Connection via connection cap
- Temperature insensitive IR-opto-receiver-ASIC with integrated signal conditioning
- Highly integrated circuit in SMD-technology
- Polarity inversion protection
- Over-voltage-peak protectio

## Absolute Rotary Encoder EXAG – Explosion Proof

### Canopen

#### Technical Data

##### Electrical Data

Interface	Transceiver according ISO 11898, galvanically isolated by opto-couplers
Transmission rate	max. 1 MBaud
Device addressing	Adjustable by rotary switches in connection cap
Supply voltage	10 – 30 V DC (absolute limits) *
Current consumption	max. 230 mA with 10 V DC, max. 100 mA with 24 V DC
Power consumption	max. 2.5 Watts
Step frequency LSB	800 kHz
Accuracy of division	$\pm \frac{1}{2}$ LSB (12 bit), $\pm 2$ LSB (16 bit)
EMC	Emitted interference: EN 61000-6-4
	Noise immunity: EN 61000-6-2
Electrical lifetime	$> 10^5$ h

\* Supply voltage according to EN 50 178 (safety extra-low voltage)

##### Mechanical Data

Housing	Aluminum	
Max. shaft loading	Axial 50 N, radial 50 N	
Inertia of rotor	$\leq 35 \text{ gcm}^2$	
Friction torque	IP65	$\leq 0.05 \text{ Nm at } 25^\circ\text{C}$
	IP67	$\leq 0.2 \text{ Nm at } 25^\circ\text{C}$
RPM max.	IP65	3,000 RPM
	IP54	6,000 RPM
	IP67	1,200 RPM
Shock (EN 60068-2-27)	$\leq 100 \text{ g (halfsine, 11 ms)}$	
Vibration (EN 60068-2-6)	$\leq 10 \text{ g (10 Hz ... 2,000 Hz)}$	
Weight (standard version)	Approx. 1200 g	
<b>Flange</b>		
<b>Clamp (C)</b>		
Shaft diameter	10 mm	
Shaft length	20 mm	

## Absolute Rotary Encoder EXAG – Explosion Proof

### Canopen

#### Environmental Conditions

Operating temperature	- 40 .. + 70°C
Storage temperature	- 40 .. + 85 °C
Humidity	98 % (without liquid state)
Protection class (EN 60529)	IP 65 (others on request)

**Note:**

For ambient temperatures below –10°C and above +60°C use field wiring suitable for both minimum and maximum ambient temperature.

#### Ex-Protection

SCANCON encoders type series EXAG are classified according to  II 2 G/D EEx d II C T6:

	II	2	G/D	EEx	d	II	C	T6
<p>Temperature Class T6: Maximum surface temperature: + 85°C</p> <p>Explosion Sub-Group C: Hydrogen (H<sub>2</sub>) , Acetylene (C<sub>2</sub>H<sub>2</sub>), Carbon Disulfide (CS<sub>2</sub>)</p> <p>Explosion Group: for all areas except for mining</p> <p>Method of protection: flameproof enclosure</p> <p>Device in compliance with EN50014 and EN50018</p> <p>Application Area: permitted for gas und dust</p> <p>Equipment-Category 2: permitted for zone 1 / zone 21</p> <p>Equipment-Group II: for all applications except for mining</p> <p>Ex-Proof Device</p>								

## Absolute Rotary Encoder EXAG – Explosion Proof Canopen

### Interface

#### Installation connection cap

The rotary encoder is connected with two or three cables depending on whether the power supply is integrated into the bus cable or connected separately. If the power supply is integrated into the bus cable, one of the cable glands can be fitted with a plug (unused cable entries have to be closed with a blind plug-> accessories). Two cable glands are suitable for cable diameters from 8 up to 9.5 mm (bus cable), one cable gland is suitable for cable diameters from 6.5 up to 8 mm (power supply).

**Follow the instructions in the installation manual carefully, otherwise the ATEX-certification will be repealed!**

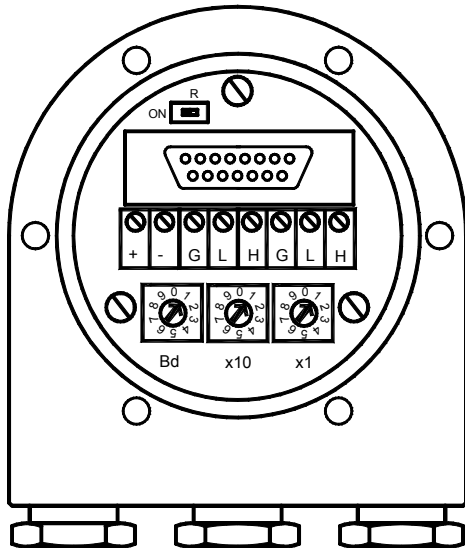

Clamp	Description
⊥	Ground
+	24 V Supply voltage
-	0 V Supply voltage
G (left)	CAN Ground (Bus In)
L (left)	CAN Low (Bus In)
H (left)	CAN High (Bus In)
G (right)	CAN Ground (Bus Out)
L (right)	CAN Low (Bus Out)
H (right)	CAN High (Bus Out)

#### Configuration connection cap

The setting of the node number is achieved by 2 turn-switches in the connection cap. Possible addresses lie between 0 and 89 whereby every address can only be used once. **Inside the encoder the defined address is increased by one.**

The baudrate is set with the third rotary switch in the cap.

The connection cap can be opened for installation by removing the six cap screws.

A termination resistor is integrated in the cap. The resistor must be switched on if the encoder is connected at the end or at the beginning of the bus:

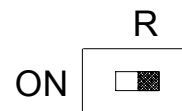

device X

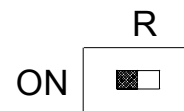

last device

Separation of Bus In and Bus Out signals if termination resistor is activated.

## Absolute Rotary Encoder EXAG – Explosion Proof

### Canopen

#### Programmable Encoder - Parameter

Operating Parameters	This parameter determines the counting direction, in which the output code increases or decreases. As an important operating parameter the code sequence (complement) can be programmed.
Resolution per Revolution	The parameter resolution per revolution is used to program the desired number of steps per revolution. Each value between 1 and the physical resolution per revolution can be programmed.
Total Resolution	This parameter is used to program the desired number of measuring units over the total measuring range. This value may not exceed the total resolution of the absolute rotary encoder. If the encoder is used in a continuous measuring application, certain rules for the setting of this parameter must be followed. These rules are outlined in the manual.
Preset Value	The preset value is the desired position value, which should be reached at a certain physical position of the axis. The position value is set to the desired process value by the parameter pre-set.
Limit Switch, Min. and Max.	Two position values can be programmed as limit switches. By reaching these values one bit of the 32 bit process value is set to high.
Cam	One free programmable cam can be set in the total measuring range. The same functionality is realized like a mechanical cam unit.

#### Programmable CAN Transmission Modes

Polled Mode	By a remote-transmission-request telegram the connected host calls for the current process value. The absolute rotary encoder reads the current position value, calculates eventually set-parameters and sends back the obtained process value by the same identifier.
Cyclic Mode	The absolute rotary encoder transmits cyclically - without being called by the host - the current process value. The cycle time can be programmed in milliseconds for values between 1 ms and 65536 ms.
Sync Mode	After receiving a sync telegram by the host, the absolute rotary encoder answers with the current process value. If more than one node number (encoder) shall answer after receiving a sync telegram, the answer telegrams of the nodes will be received by the host in order of their node numbers. The programming of an offset-time is not necessary. If a node should not answer after each sync telegram on the CAN network, the parameter sync counter can be programmed to skip a certain number of sync telegrams before answering again.

# Absolute Rotary Encoder EXAG – Explosion Proof

## Canopen

### Mechanical Drawings

Clamp flange (C)

Shaft

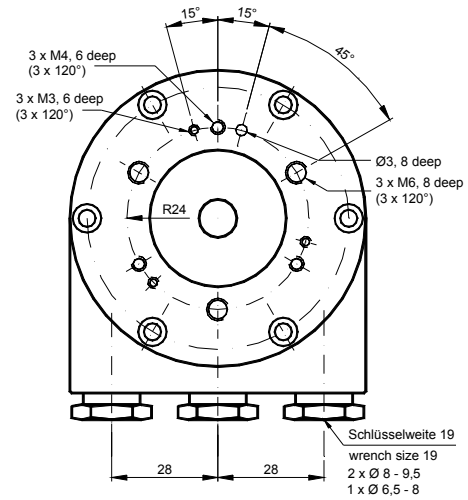
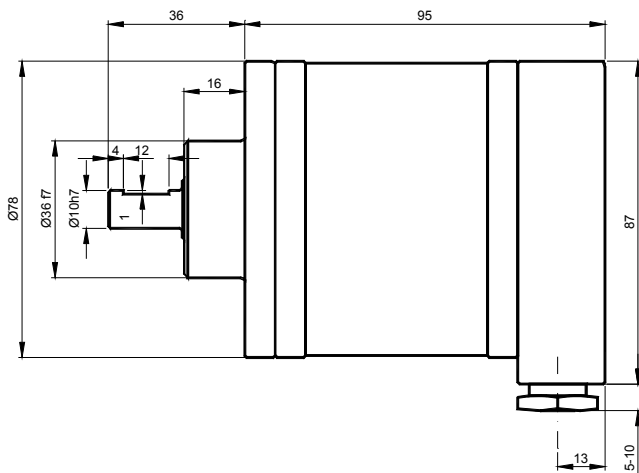

### Hollow Shaft

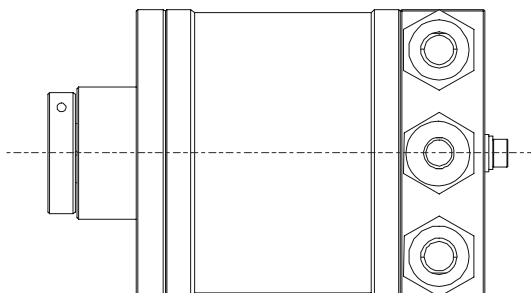
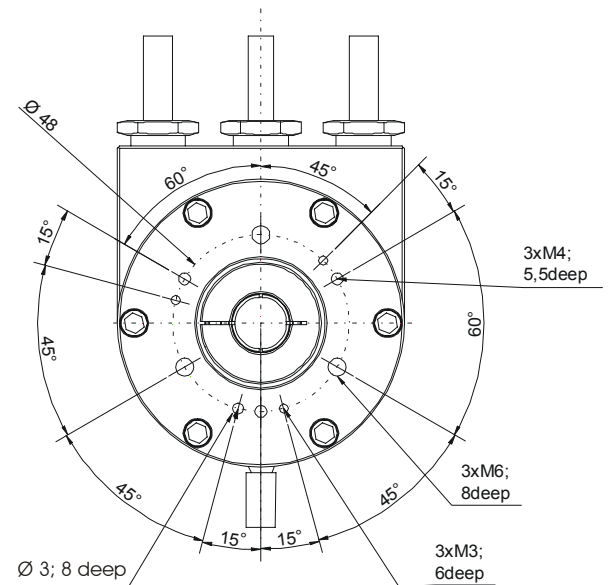
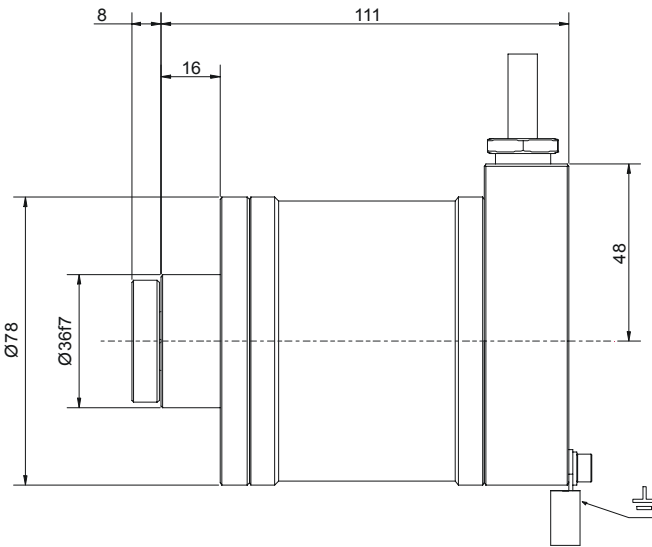

18 Clifton Road, Coulsdon, Surrey, CR5 2DU, UK  
Tel: +44 (0)20 8405 0918 Fax: +44 (0)20 8660 5591  
Email: [enquiries@pca Ltd.net](mailto:enquiries@pca Ltd.net) Web: [www.pca Ltd.net](http://www.pca Ltd.net)

## Absolute Rotary Encoder EXAG – Explosion Proof

### Canopen

#### Models/Ordering Description

Description	Type key
Ex-Proof Optocode	<b>EXAG-</b> -- -- -- -- -- -- -- -- -- -- -- -- -- -- -- --
Interface	Canopen <b>C2</b>
Version	<b>B1</b>
Code	Binary <b>B</b>
Revolutions (Bits)	Singleturn <b>00</b> Multiturn (4096 revolutions) <b>12</b> Multiturn (16384 revolutions) 14
Steps per Revolution	4096 12
(Bits)	8192 <b>13</b>
Shaft or	Solid Shaft <b>A</b>
Hollow Shaft	Hollow Shaft H
Material	Aluminum <b>AL</b> Stainless Steel VA
Shaft diameter	10 mm <b>10</b>
Shaft length	20 mm <b>20</b>
Hollow shaft diameter	14 mm 14
Deep	35 mm 35
IP Rating	IP65 (further on request) <b>65</b>
Flange	Clamping Flange <b>C</b>
Connection	Connection Cap Field Bus – radial cable outlets <b>FS</b> 2 x Ø 8-9.5 mm / 1 x Ø 6.5 - 8 mm Hydraulic Hose HS

**Standard = bold**, further models on request

#### Accessories and Documentation

Description	Type
Shaft coupling	Drilling: 10 mm GS 10
EDS-File*	Disc containing EDS-file for configuration. DK-CA
Blind Plug	Blind plug for unused cable entries EXAG-BL

\* Can be downloaded free of charge from our homepage [www.scancon.dk](http://www.scancon.dk)

We do not assume responsibility for technical inaccuracies or omissions. Specifications are subject to change without notice.