

9 mm diameter Encoder up to 1000 ppr. - True lines. 6 channels up to 4000 Counts

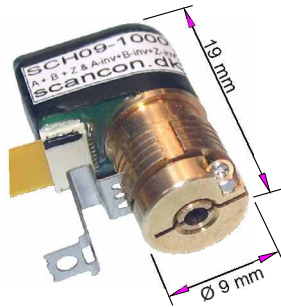

CHARACTERISTICS

ENCODER TYPE	Nano hollow through shaft encoder
SMD - TECHNOLOGY	Strong compact electronics
HIGH IP-RATING	Std. IP 54
LOW CURRENT CONSUMPTION	To be connected directly to PLC'S and counters
SHORT CIRCUIT PROTECTION	Thermal shut down at 155°C
POWER SUPPLY	5V ± 10% (TTL)
STRONG MEC. CONSTRUCTION	Based on 2 precision ballbearings for industrial environments

ELECTRICAL SPECIFICATIONS

	At +25°C
Output	Totempole
Output waveform	Incremental (A, B)
Zero or index pulse	(Z) one pr./rev.
Supply-voltage	5V ± 10%
Current (no load)	35mA
Max. load pr. output	20mA
V out low	Max 500 mV at I out low = 10 mA
Operating temp.	-20°C to +70° C
Storage temp.	-20° C to +85°C
Max. pulse frequency	200 kHz
V out high	Min. (Vin -0,6) @ I = -10mA Min. (Vin -1,3) @ I = -25mA
Cable data	
Output signals	Differential (RS-422A compatible)
Certified acc. To	EN 50081-1 and EN 50082-2*

MECHANICAL SPECIFICATIONS

Weight, excl. Cable	About 15 g
Materials:	
Housing	Brass
Shaft	Brass
Bearings	Lifetime lubricated ball-bearings
Fixing clamp	Brass
H.-Shaft dimensions	ø2,0mm
H.-Shaft loads	Axial max. 2 N Radial max. 2 N
Max speed	12,000 rev./min.
IP-rating	IP 54
Start torque	<0,001 Nm at 25°C
Massmoment of inertia	0.05 gcm ²
Max. shock	100 G/11 ms.
Bump	10 G - 16 ms (1000 x 3axis)
Vibration	(10 - 2000 Hz)/10 G

OUTPUT CIRCUIT

Flex Printout

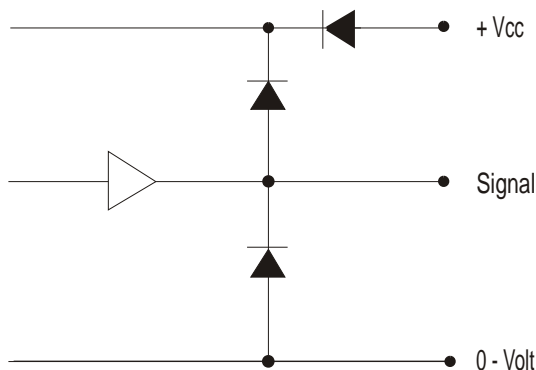

MECHANICAL DIMENSIONS

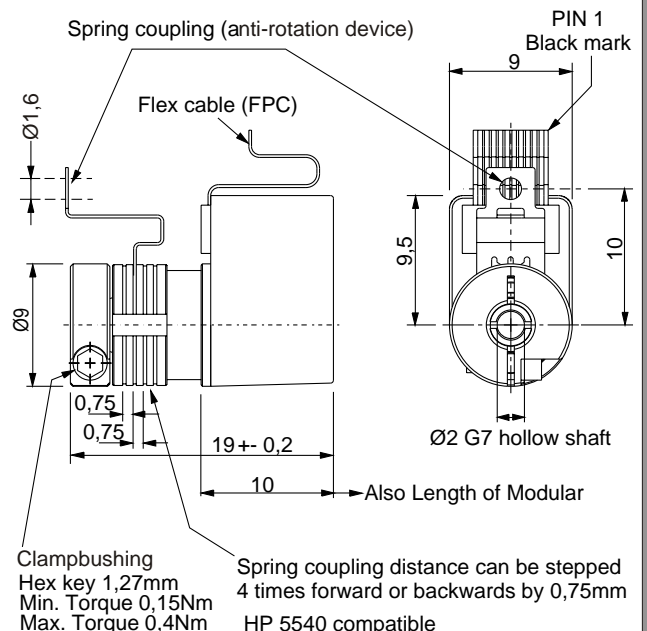

OUTPUT WAVEFORM

Rotation: Clockwise (cw) from shaftside

(inv = inverted channels)

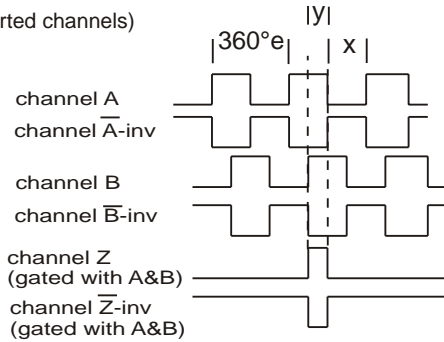

$X = 180^\circ e \pm 36^\circ e$ and $Y = 90^\circ e \pm 18^\circ e$
Z puls: Gated with A and B (standard)

Options: Open Collector NPN or PNP
Gated Z-puls or none-gated Z-puls.
View more Output options in section 15 - page 1

CONNECTIONS FPC

Output: Flex print cable (FPC) **Pin 1 (Black)**

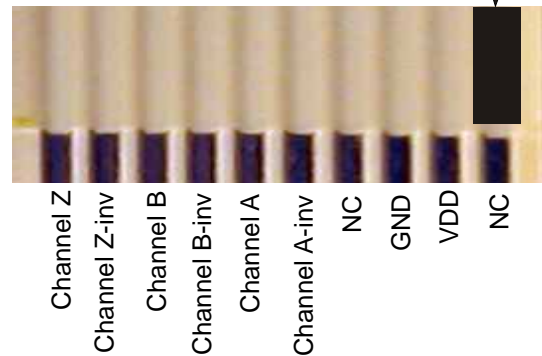

Mating connector: **Pin 1 (Black)**
JST 10FHJ-SN1-TB or equivalent

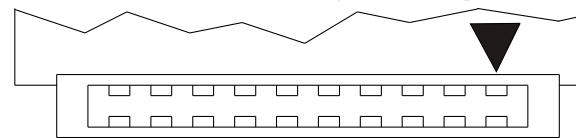

ORDERING CODES

	Option	Ordering code
SCH09-S	Standard	S
SCH09-V	Vacuum	V
SCH09-M	Modular	M
Pulses pr. rev.:	No. of pulses	XXXX
Output signal:	TP-Differential, 6 channel A, B, Z and A-inv, B-inv, Z-inv	D
H.-Shaft dimensions:	ø2,0mm	2,0
IP-rating:	IP 54	54
Cable take out:	Side	S
Cable length:	50 mm	0,05 meter
	100 mm	0,10 meter
	200 mm	0,20 meter

PULSES/REV.

1000

Other pulses are under construction

Please ask if we now have the pulses/rev you need

SCH09-S (Standard) Hollow Through Shaft

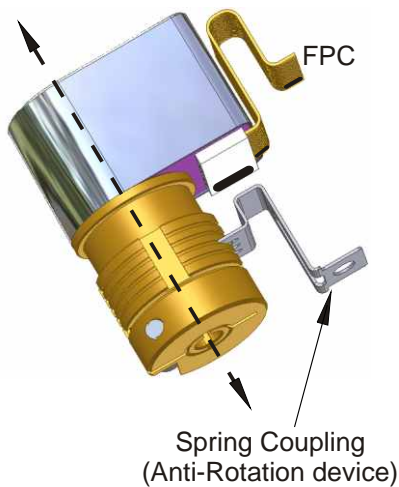

Option Type: S

SCH09-V (Vacuum) Flying Sleeve Bushing

Hollow through shaft
for vacuum hose

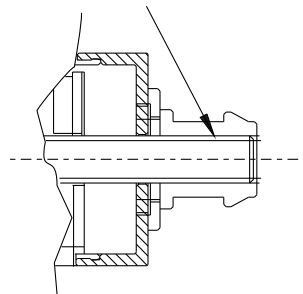

Option Type: V

SCH09-M (Modular) Modular Encoder

NOTE:
No Ballbearings. Motor must
have preloaded ballbearings.

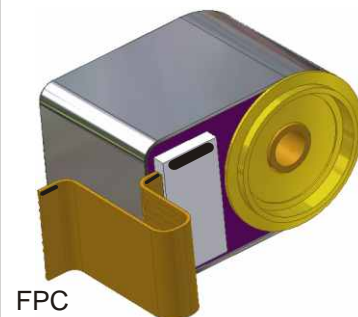

Option Type: M

SCH09



Option
Type

1 0 0 0

Pulses



Output signal

0 2

H.-Shaft

5 4

IP-Rating

0, 0

Cable length



Cable take out