

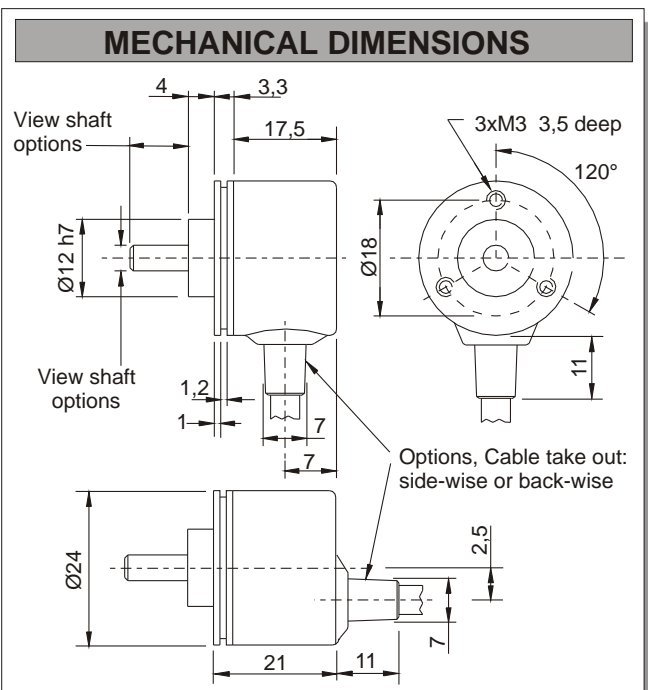

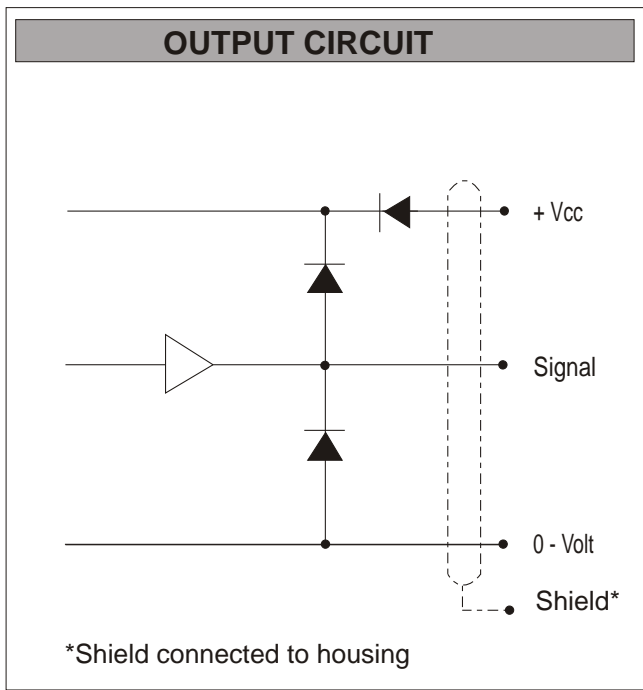

CHARACTERISTICS	
ENCODER TYPE	Shaft encoder
SMD - TECHNOLOGY	Strong compact electronics
HIGH FREQUENCY	200 kHz version
HIGH IP-RATING	Std. IP 65
LOW CURRENT CONSUMPTION	To be connected directly to PLC's and counters
SHORT CIRCUIT PROTECTION	Thermal shutdown at 155°C
WIDE SUPPLY RANGE	Min. 4,5V to max. 30V
STRONG MECH. CONSTRUCTION	Based on 2 precision ball bearings for industrial environments

ELECTRICAL SPECIFICATIONS	
	At +25°C
Output	Totempole
Output waveform	Incremental (A, B)
Zero or index pulse	(Z) one pr./rev.
Supply-voltage (Vin)	Min 4,5V to Max. 30V * Reverse polarity protection
Current (no load)	35mA
Max. load pr. output	20mA*
V out low	Max. 500 mV @ I = 10mA
Operating temp.	-40°C to +85°C
Storage temp.	-40°C to +85°C
Max. pulse frequency	200 kHz*
V out high	Min. (Vin - 0,6) @ I = -10mA Min. (Vin - 1,3) @ I = -25mA
Cable data	5(0,14mm <sup>2</sup> ) or 8-leads(0,05mm <sup>2</sup> ) shielded
Output signals	Standard Inverted Differential
Certified acc. to	EN 50081-1 and EN 50082-2
	* = It is not recommended to combine max value for all 3 parameters

MECHANICAL SPECIFICATIONS	
Weight	About 35 g (+cable = 0,040 Kg/meter)
Materials: Housing	Electroplated steel and brass
Shaft	Stainless steel
Bearings	Lifetime lubricated ball bearings
Shaft dimensions	View Ordering Code, next page
Shaft loads	Axial max. 20 N Radial max. 20 N
Max. rev.	9000 rev./min.
IP-rating	Standard IP 65
Start torque	<0,05 Nm at 25°C
Mass moment of inertia	0,8 gcm <sup>2</sup>
Max. shock	100 G/11 ms.
Bump	10 G - 16 ms (1000 X 3 axis)
Vibration	(10 - 2000 Hz)/10 G



## OUTPUT WAVEFORM

 Rotation: Clockwise (cw) from shaftside

(inv = inverted channels)

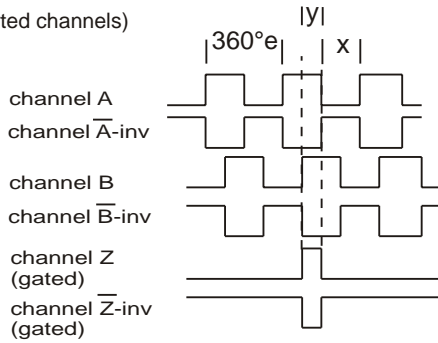

$X = 180^\circ e \pm 36^\circ e$  and  $Y = 90^\circ e \pm 18^\circ e$   
Z puls: Gated with A and B (standard)

Options: TTL or HTL compatible. Open Collector NPN or PNP  
Gated Z-puls or none-gated Z-puls.  
View more Output options in section 15 - page 1

## CONNECTIONS

Color code	Standard	Color code	Differential
Green	Ch A	Pink	Ch A
Yellow	Ch B	Grey	Ch A inv
Grey	Ch Z	Green	Ch B
Brown	Vcc	Yellow	Ch B inv
White	0-Volt	White	Ch Z
		Brown	Ch Z inv
		Red	Vcc
		Blue	0-Volt

## PULSES/REV.

4	30	100	250	600	2048
10	36	125	256	1000	2500
11	50	128	300	1024	3000
12	60	150	360	1250	3600
15	75	180	400	2000	5000
25	90	200	500	2500	7500

## ORDERING CODES

	Options	Ordering codes
Pulses pr.rev.:	No. of pulses	XXXX
Output signal:	Normal (TP-Standard) 3 channel = A, B, Z	N
	TP-Differential, 6 channel A, B, Z and A-inv, B-inv, Z-inv	D
Shaft dimensions:	ø4 x 9 mm	04 x 09
	ø4 x 15 mm	04 x 15
	ø4 x 20 mm	04 x 20
	ø6 x 14mm	06 x 14
IP-rating:	IP 65	65
Round Cable	Standard 1 meter	01
Length of cable:	No. of meters	XX
Round Cable	Side	S
Cable take out:	Back	B
Cable and connector options:	View section 20 page 10 to 13	
Anti rotation spring coupling or Flange / Plate:	View Section 9 page 1 to 6	

## Flat Ribbon Cable and/or Connector

### Options

Flat Cable (only IP 50)  
Ribbon + IDC or AMP  
View Section 20 page 10

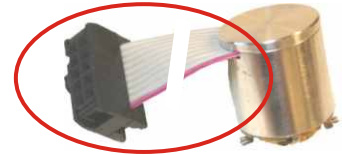

Connector on Encoder:  
(only IP64)  
View Section 20 page 11

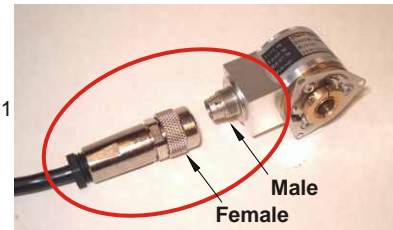

## Advanced Output Options:

Options	Ordering codes
Normal Open Collector NPN	NON
Differential Open Collector NPN	DON
Normal Open Collector PNP	NOP
Differential Open collector PNP	DOP

To order replace  with

Output signal      Output signal

2RM-IP65

Pulses

Output signal

Shaft

 X  

Shaft length

IP-rating

Length of round cable

Cable take out

Anti Rotation Spring Coupling Or Flange / Plate Order Number