



CHARACTERISTICS

ENCODER TYPE	Shaft encoder
SMD - TECHNOLOGY	Strong compact electronics
HIGH FREQUENCY	200 kHz
HIGH IP-RATING	Std. IP 64 (option; Ribbon cable + IDC connector = IP50)
LOW CURRENT CONSUMPTION	To be connected directly to PLC's and counters
SHORT CIRCUIT PROTECTION	Thermal shutdown at 155 C
WIDE SUPPLY RANGE	Min. 4,5V to max. 30V
STRONG MECH. CONSTRUCTION	Based on 2 precision ball bearings for industrial environments

ELECTRICAL SPECIFICATIONS

At +25°C	
Output	Totempole, (OC on request)
Output waveform	Incremental (A, B)
Zero or index pulse	(Z) one pr./rev.
Supply-voltage (Vin)	Min 4,5V to Max. 30V * Reverse polarity protection
Current (no load)	35mA
Max. load pr. output	20mA*
V out low	Max. 500 mV @ I = 10mA
Operating temp.	-40°C to +85°C
Storage temp.	-40°C to +85°C
Max. pulse frequency	200 kHz*
V out high	Min. (Vin - 0,6) @ I = -10mA Min. (Vin - 1,3) @ I = -25mA
Cable data	5(0,14mm ²) or 8-leads(0,05mm ²) shielded
Output signals	Standard Inverted Differential (RS-422A compatible)
Certified acc. To	EN 50081-1 and EN 50082-2
* = It is not recommended to combine max value for all 3 parameters	

MECHANICAL SPECIFICATIONS

Weight	About 60 g (+cable = 0,040 Kg/meter)
Materials: Housing	Electroplated steel and brass
Shaft	Stainless steel
Bearings	Lifetime lubricated ball bearings
Shaft dimensions	1/8" (ø3,175mm) x 15 mm
Shaft loads	Axial max. 20 N Radial max. 20 N
Max. rev.	12,000 rev./min.
IP-rating	Standard IP 64
Start torque	<0,005 Nm at 25°C
Mass moment of inertia	0,8 gcm ²
Max. shock	100 G/11 ms.
Bump	10 G - 16 ms (1000 X 3 axis)
Vibration	(10 - 2000 Hz)/10 G

OUTPUT CIRCUIT

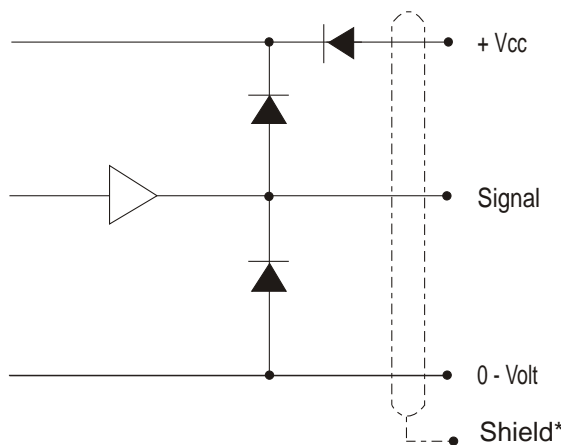

*Shield connected to housing

MECHANICAL DIMENSIONS

