

LVDT

Inductive Position Transducer

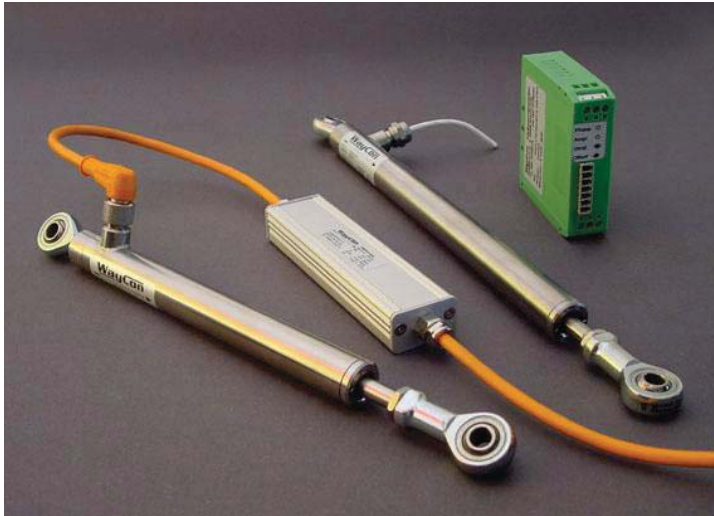

Series SL \varnothing 20 mm

- **ranges 50...300 mm**
- **\varnothing 20 mm**
- **out: AC, 0...10 V, 0...5 V, 4...20 mA**
- **linearity 0,3%**
- **rugged stainless steel housing**
- **diameter push rod: 8 mm**
- **temperature -40...+120°C (150°C optional)**
- **customised version available**

Technical Datas

Sensor

range [mm]	0...50	0...80	0...100	0...150	0...200	0...300	0...600 (optional)
linearity	0,3% (0,2% optional)						
types	free core, push rod guided/unguided, rod end bearing						
bearing material	Iglidur bearing						
protection class	IP65 or. IP68 / 10 bar						
vibration stability DIN IEC68T2-6	10G						
shock stability DIN IEC68T2-27	200 G/2 ms						
supply voltage/frequency	3 Veff / 3 kHz						
supply range	0,5...8 Veff						
supply frequency	2...10 kHz						
temperature range	-40...+120°C (150° optional)						
mounting	ø20 mm clamp diameter						
connection	4 core PTFE-cable, PUR/ PVC-cable or M12-connection, coupling nut						
housing	stainless steel 1.4301						
cable -PVC (standard)	ø4,7 mm, 2 twisted pair PVC-cores, 0,16 mm ²						
-PTFE (optional)	ø3,7 mm, 0,24 mm ² , max. temp. 205°C						
-PUR (optional)	ø3,9 mm, 0,14 mm ² , non halogen, highly flexible						
max. cable length	100 m between sensor and IMA external electronics						
free core / push rod							
max. acceleration of core / push rod	100G						
life time	infinite						
weight (without cable) [g]	230 g	290 g	320 g	360 g	420 g	940 g	

Electronics

output signal	0...20 mA, 4...20 mA (load <500 Ohm) 0...5 V, ±5 V (load >5 kOhm) 0...10 V, ±10 V (load >10 kOhm)
temperature coefficient	zero 150 ppm/°C, max. value 400 ppm/°C
ripple	< 20m Veff
max. frequency	300 Hz/-3 dB (Butterworth 5'th rang)
adjustment range	Offset ±20%, gain ±50%
isolation resistance	> 1 G Ohm at 500 VDC
isolation stability	supply <> signal 500 VDC
power supply	24 VDC (18..36 V) or 15 VDC (9..18 V)
current consumption	<150/80 mA with/without load (supply 24 VDC)
VDC)	
sensor supply	3 Veff, 3 kHz
working temperature	0...+60°C
storage temperature	-20...+80°C
housing	meets UL94-VO
mounting	on DIN rail

KAB cable electronics

output signal	0...20mA, 4...20mA (load <100 Ohm) 0...5 V, ±5 V (load > 5kOhm) 0...10 V (load >10kOhm)
temperature coefficient	460ppm/°C
ripple	< 20m Veff
max. frequency	-
adjustment range	-
isolation resistance	-
isolation stability	-
power supply	24 VDC (18..36 V) or 15 VDC (9..18 V)
current consumption	65 mA (24 VDC), 140 mA (12 VDC) <300/100 mA with/without load (supply 15 VDC)
sensor supply	3,0 Veff (15...26V-supply) 2,4 Veff (12...20V-supply)
working temperature	0...+60°C
storage temperature	-20...+80°C
housing	aluminium shotpeeled
mounting	none

The output signal is referring to the electric measuring range. If the sensor is operated outside the measuring range or the measuring range is exceeded, then the signal is also outside the defined range (i.e. >10V/20mA or <0V/4mA, in the graph: >100% or <0%).

Please keep this in mind for control systems with cable break detection lower than 4mA or for a maximum input voltage >10V of measuring instruments. If necessary install the sensor **before** connecting to the plc.

Running direction of signal: If the push rod is moving into the sensor (e.g. sprung load pushed in), then the signal is reducing. If the push rod is moving out, then the output signal is increasing. The running direction of the signal can also be inverted.

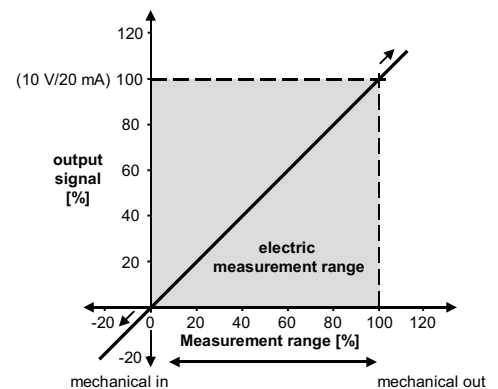

Technical Dimensions

range (FS) [mm]	body length [mm]	core length [mm]	push rod length [mm]
0...50	187	70	177
0...80	247	100	237
0...100	287	120	277
0...150	387	170	377
0...200	487	220	477
0...300	687	320	677

type: free core / guided or unguided push rod

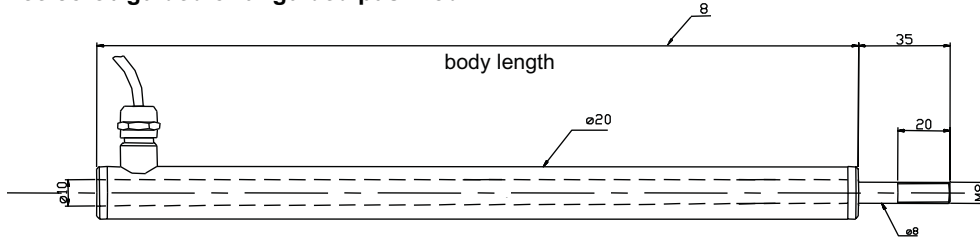

core, push rod

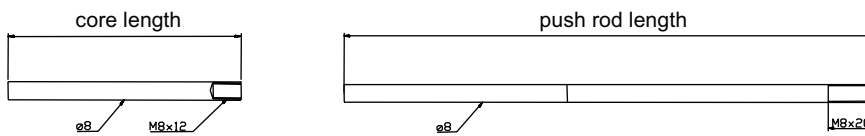

push rod guided

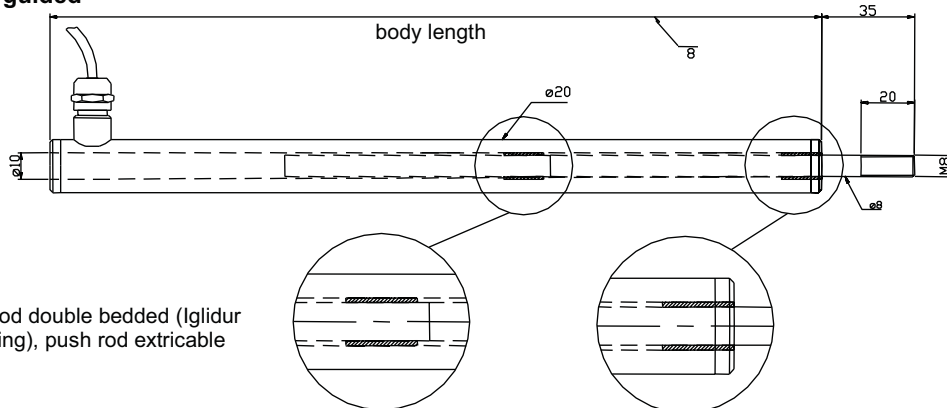

push rod double bedded (Iglidur bearing), push rod extricable

rod end bearing

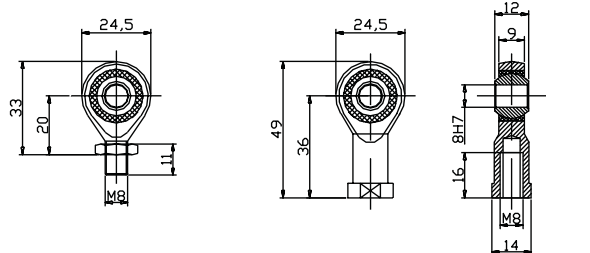
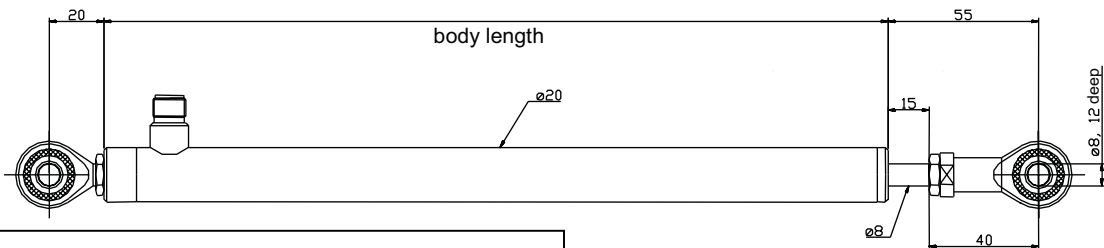

Cable outputs (optional)

Radial cable output

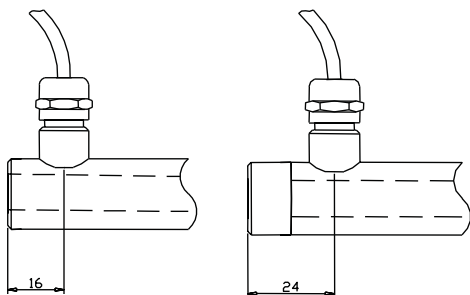

Sensor with a radial cable output have a through hole. Please use this type for application at heavy dirt exposure. The movement of the push rod removes the dirt from the sensor and conveys it to the rear. The standard cable length is 2m.

Depending on the application the sensor can - on request - be supplied with a closed rear end body (without additional charge). Please specify that in your order.

Connector output (cable with straight or angular connector)

For sensors with a connector output a cable has to be ordered separately. Cables with a straight connector, as well as cables with angular connectors are available.

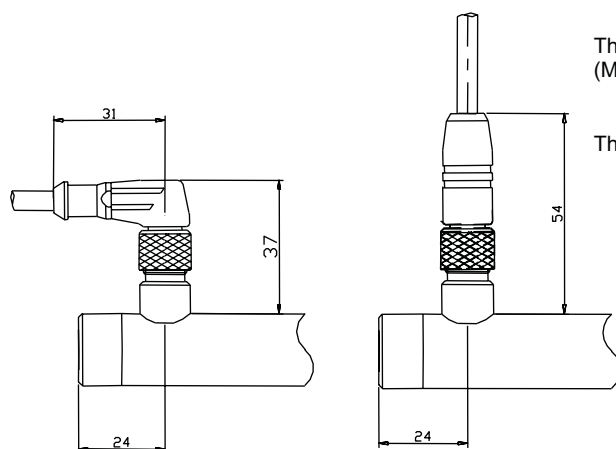

The connector is protected from accidental removal by a threaded fitting (M12). The cable lengths are 2/ 5/ 10m.

The connector pair has protection class IP65.

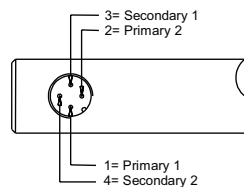

Wiring diagram

Adjustment of zero point and amplification of the electronics

Please note that zero point and amplification may shift for long cable lengths between sensor and electronics. Thus install the sensor with the according line length to the electronics and then adjust zero point and amplification.

1. Push rod entirely in - adjust offset:

Move the sensor to the zero point of the measuring range and set the offset potentiometer on 0mA, i.e. 0V for the output signal.

2. Push rod entirely out - adjust amplification:

Move the sensor to the mechanical end point (push rod moved out) and set the amplification potentiometer on 16mA/ 10V/ 5V for the output signal.

3. Adjust offset (4...20mA output)

Set the offset potentiometer on 20mA (+4mA) for the output signal.

Signal inversion

If an inverted output signal is required (20...4mA/ 10...0V/ 5...0V), then swap clamps 6 and 8 (secondary coil) on the external electronics.

AC-output

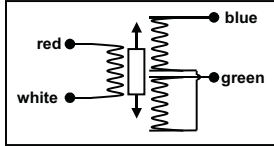

wiring diagram:
 white (5): Primary 2
 green/black (6): Secondary 2
 red/brown (9): Primary 1
 blue (8): Secondary 1

wiring diagram for PTFE-connection:
 white (5): Primary 2
 green(6): Secondary 2
 yellow (9): Primary 1
 brown (8): Secondary 1

Cable electronics KAB

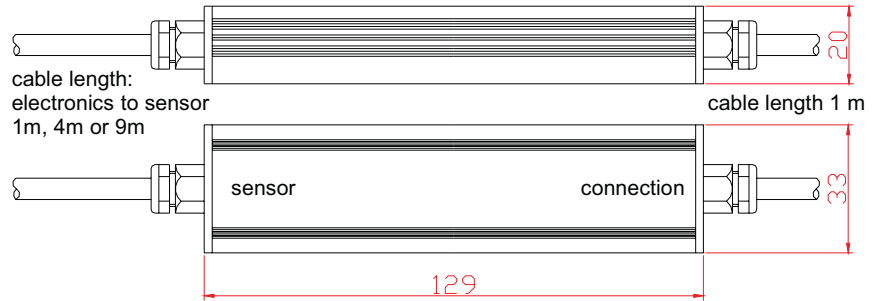

If not specified otherwise the cable electronics is situated at 1m from the end of the cable. On request in your order, however, the cable electronics is available at any distance.

wiring diagram:
 brown/red: supply V+
 blue: GND
 black/green: output GND
 white: output signal

wiring diagram for PTFE-connection:
 yellow: supply V+
 brown: GND
 green: output GND
 white: output signal

External electronics IMA



external electronics IMA (for DIN rail mounting)

dimensions:

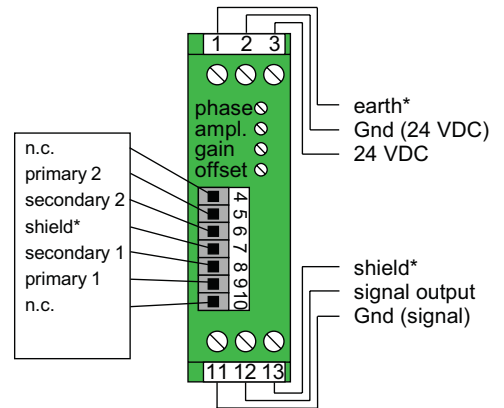
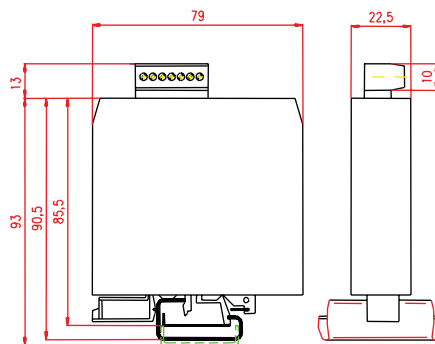

* clamps 1, 7 u. 13 are internally connected

connection:

The external electronics IMA2-LVDT is designed to be installed in switch cabinets (DIN-rail mounting). The connection to the sensor is conducted as connector with screw clamps.

At harsh EMC environments, it is possible to install the electronics at a max. distance of 100 m in a switch cabinet. A twin twisted pair cable (4-cores, minimum cross section 0,5 mm²), single or double shielded, is to be used for the further wiring to connect the external electronics to the system. It is recommended to ground the shield in the switch cabinet near the electronics (do not ground at the machine / sensor). The sensor housing is grounded at the machine frame. To prevent interference, the cable length should not exceed 100 m.

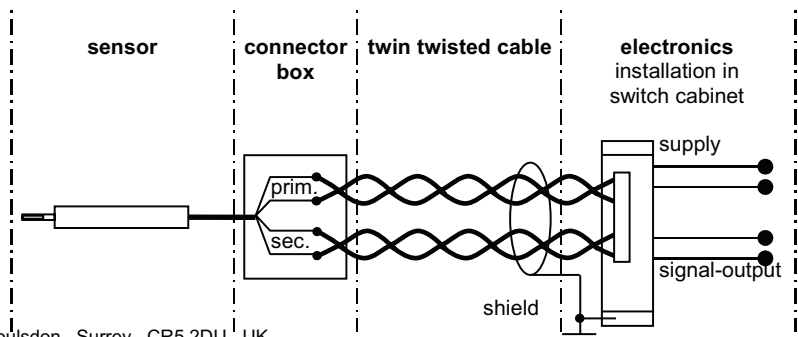

Order Code

