

ABSOLUTE MAGNETIC ROTARY ENCODER CANOPEN



High-resolution absolute encoder based on magnetical technology. Singleturn encoding based on 360° Hall technology. Multiturn encoding based on magnetic pulse counter. No batteries used.

Main Features

- Compact industrial model
- Interface: CANopen
- Housing: 36,5 mm Ø
- Shaft: 6 mm Ø
- Blind hollow shaft 6 mm Ø
- Max. 16.384 steps/revolution (typical 12 bit)
- Max. revolution not limited (typical 14 bit)
- EMC: EN 61000-6-2, EN 61000-6-4

Programmable Parameters

- Baud rate and CAN-Identifier
- Resolution per revolution
- Total resolution
- Direction of rotation (complement)
- Preset value
- Two limit switches
- Transmission mode: Polled mode, cyclic mode, sync mode

Mechanical Structure

- Aluminum flange
- Nickel-plated steel housing
- Stainless steel shaft
- Precision ball bearings with sealing or cover rings

Electrical Features

- Highly integrated circuit in SMD -technology
- Polarity inversion protection
- Over-voltage-peak protection
- Galvanic Isolation

ABSOLUTE MAGNETIC ROTARY ENCODER CANOPEN

Technical data

Electrical data

Baudrate	max. 1 MBaud
Supply voltage	10-30 V DC (absolute maximum ratings) *
Power consumption	about 0,5 W
Electrical lifetime	> 10 ⁵ h
EMC	Emitted interference: EN 61000-6-4
	Noise immunity: EN 61000-6-2
Connection	cable exit

* Supply voltage according to EN 50 178 (safety extra-low voltage)

Sensor data

Singleturn technology	magnetic 2 axis Hall sensor
Singleturn resolution	up to 16.384 steps / revolution (14 Bit)
Singleturn accuracy	+/- 1.5° not calibrated (MCD-CA00B version)
	+/-0,35° calibrated (MCD-CA00C version)
Internal cycle time Singleturn	< 600 μ s
Multiturn technology	self supplied magnetic pulse counter
Multiturn resolution	Can measure up to 200 Billion revolutions

Environmental Conditions

Operating temperature	- 30 ... + 70 °C (static mounted cable) *
Storage temperature	- 30 ... + 70 °C
Humidity	98 % (without liquid state)
Protection Class (EN 60529)	Casing side: IP 54
	Shaft side: IP 54

* depends on used cable. Higher temperature resistance on demand

ABSOLUTE MAGNETIC ROTARY ENCODER CANOPEN

Mechanical data

Housing	Nickel-plated iron housing		
Flange	Aluminium		
Shaft	Stainless steel		
Lifetime	Dependent on shaft version and shaft loading – refer to table		
Max. shaft loading	Axial 40 N, radial 110 N		
Inertia of rotor	$\leq 30 \text{ gcm}^2$		
Friction torque	$\leq 3 \text{ Ncm}$		
RPM (continuous operation)	max. 12.000 RPM		
Shock (EN 60068-2-27)	$\leq 100 \text{ g}$ (half sine, 6 ms)		
Permanent shock (EN 60028-2-29)	$\leq 10 \text{ g}$ (half sine, 16 ms)		
Vibration (EN 60068-2-6)	$\leq 10 \text{ g}$ (10 Hz ... 1,000 Hz)		
Weight (standard version)	$\approx 150 \text{ g}$, including cable		
Flange			
	Synchro (S)	Blind hollow shaft (B)	Clamp (C)
Shaft diameter	6 mm	6 mm	10 mm
Shaft length	11,5 mm	-	20 mm-
Hollow shaft depth min. / max.	-	8 mm / 18 mm	-

Minimum (mechanical) lifetime

Flange	Lifetime in 10^8 revolutions with F_a / F_r		
	40 N / 60 N	40 N / 80 N	40 N / 110 N
S6 Synchro flange	216	91	35

Cable

Operating temperature cable	flexing -5°C bis +70°C static -30°C bis +70°C
Minimum bend radius	flexing 10x cable diameter static 5x cable diameter
Cable	aprox 6 mm \varnothing / type : LIYCY 4x2x0.14

ABSOLUTE MAGNETIC ROTARY ENCODER CANOPEN

Interface

Configuration

The standard configuration of the encoder is: node number 32 and baud rate 20 Kbaud. For adapting the encoder for a respective application the customer could use SDO telegrams. Valid baud rate range is 20 kbaud up to 1Mbaud and node numbers from 0 to 127.

Remark: The encoder adds internal 1 to the adjusted node number.

Electrical interface

The standard connection is a cable with a RJ45 connector. 5 pin circular plug M12 and cable exit are available too (For pin assignment see table below).

Function	Wire end	Connector Pin RJ45	Connector Pin M12
Can High	white	1	4
Can Low	brown	2	5
Can-GND	green	3	1
GND	yellow	4	3
+ U _b = 10-30 V	red	8	2

5 pin M12 connector male

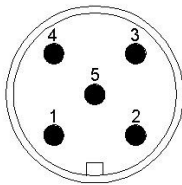

RJ45 Connector

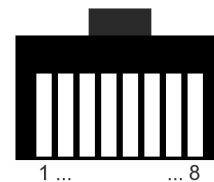

ABSOLUTE MAGNETIC ROTARY ENCODER CANOPEN

Programmable Encoder - Parameter

Operating Parameters	This parameter determines the counting direction, in which the output code increases or decreases. As an important operating parameter the code sequence (complement) can be programmed.
Resolution per Revolution	The parameter resolution per revolution is used to program the desired number of steps per revolution.
Total Resolution	This parameter is used to program the desired number of measuring units over the total measuring range. This value may not exceed the total resolution of the absolute rotary encoder. If the encoder is used in a continuous measuring application, certain rules for the setting of this parameter must be followed. These rules are outlined in the manual.
Preset Value	The preset value is the desired position value, which should be reached at a certain physical position of the axis. The position value is set to the desired process value by the parameter pre-set.
Limit Switch, Min. and Max.	Two position values can be programmed as limit switches. By reaching these values one bit of the 32-bit process value is set to high.
Cam	Eight position values can be programmed as cams. By reaching these values bits in object 6300h Cam state register are set.

Programmable CAN Transmission Modes

Polled Mode	By a remote-transmission-request telegram the connected host calls for the current process value. The absolute rotary encoder reads the current position value, calculates eventually set-parameters and sends back the obtained process value by the same identifier.
Cyclic Mode	The absolute rotary encoder transmits cyclically - without being called by the host - the current process value. The cycle time can be programmed in milliseconds for values between 1 ms and 65536 ms.
Sync Mode	After receiving a sync telegram by the host, the absolute rotary encoder answers with the current process value. If more than one node number (encoder) shall answer after receiving a sync telegram, the answer telegrams of the nodes will be received by the host in order of their node numbers. The programming of an offset-time is not necessary. If a node should not answer after each sync telegram on the CAN network, the parameter sync counter can be programmed to skip a certain number of sync telegrams before answering again.

ABSOLUTE MAGNETIC ROTARY ENCODER CANOPEN

Mechanical Drawings

Blind hollow shaft (B)

Cable exit or
5 pin male M12 Connector

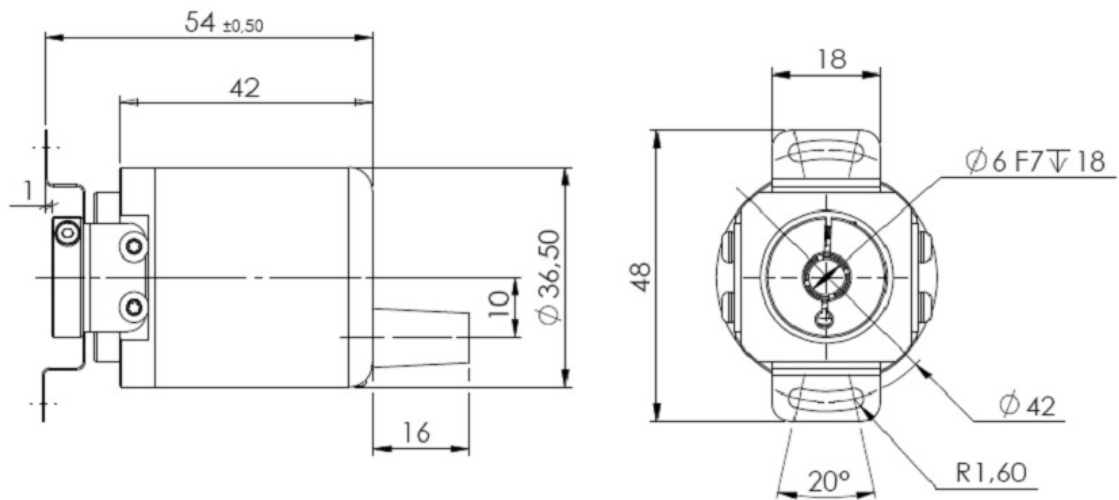

Synchro Flange (S)

Cable exit or
5 pin male M12 Connector

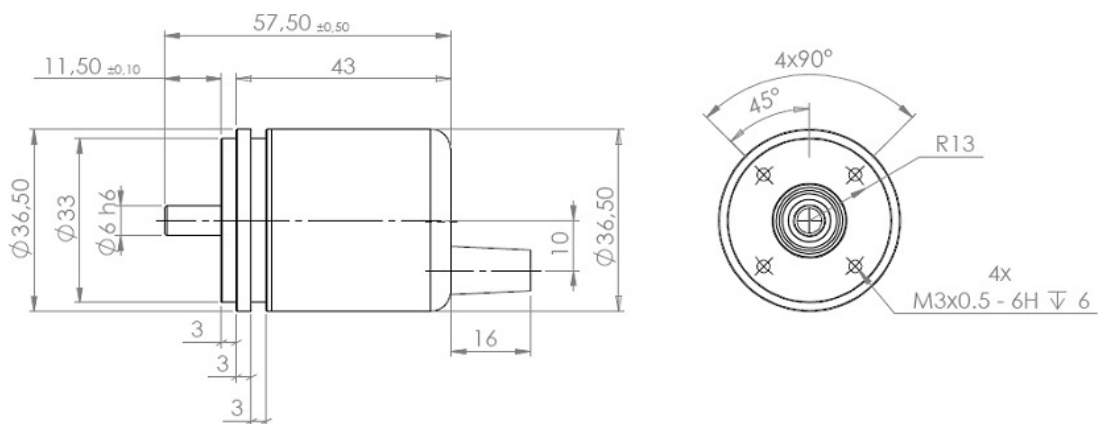

ABSOLUTE MAGNETIC ROTARY ENCODER CANOPEN

Clamp Flange (C)

Cable exit or

5 pin male M12 Connector

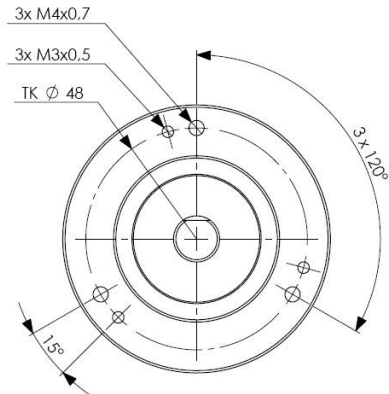
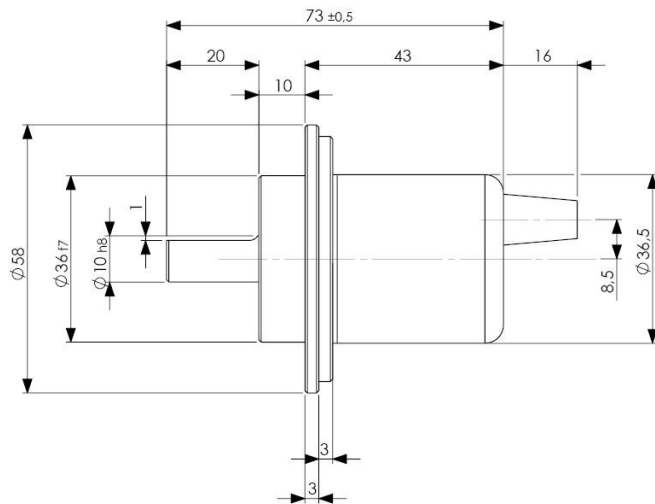

5 pin male M12 Connector

Flange and housing dimensions from Synchro Flange

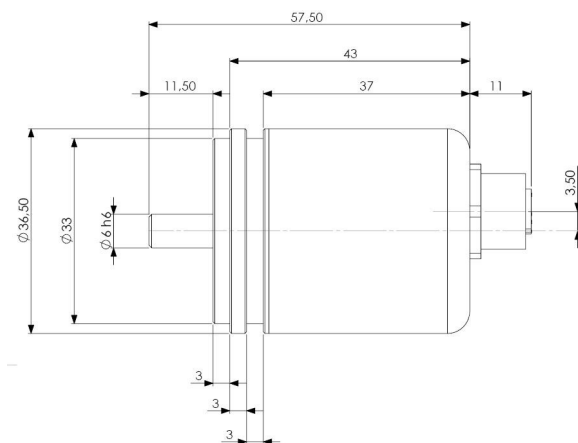

ABSOLUTE MAGNETIC ROTARY ENCODER CANOPEN

Models / Ordering Description

Description

Magnetocode	MCD-	C_	00	—	—	—	—	—	—	
Interface and Version	CANopen	CA								
	CANopen lift (DSP417)	CL								
Current Version	CA		00							
	CL		00							
Code	Binary			B						
Bits for Revolutions	Single turn					00				
	Multi turn (4.096 turns)					12				
	Multi turn (65.536 turns)					16				
Steps per revolution (Bits)	4.096						12			
Flange	Synchro flange							S		
	Blind hollow shaft							B		
	Clamp flange							C		
Shaft diameter	06 mm (Flange S and B)								06	
	10 mm (Flange C)								10	
Mechanical options	Without								0	
	Customized								C	
Connection	Cable exit, axial 1m									CAW
	Connector, axial, 5 pin male M12									PAM

Standard = bold, further models on request

Ordering example :

MCD-CA00B-1612-S060-CAW